

CHNT

Empower the World



NM8N Moulded Case Circuit Breakers

Air Circuit Breaker

MCCB



NM8N

Page P-001



NM1

Page P-087

NM8N Moulded Case Circuit Breaker

- 1 Body
- 2 Thermo magnetic release
- 3 Electronic release
- 4 Communication module
- 5 **Battery box**
- 6 Cable connector
- 7 Front connection plate
- 8 Rear connection plate
- 9 Cage clamp terminal
- 10 Residual current protection module
- 11 Long terminal cover
- 12 Short terminal cover
- 13 Direct rotary handle
- 14 Economic extended rotary handle
- 15 Extended rotary handle
- 16 Motor driven operating mechanism
- 17 Mechanical interlock
- 18 Locking system
- 19 Closing electromagnet
- 20 Under-voltage release
- 21 Shunt release
- 22 Alarm contact
- 23 Auxiliary contact
- 24 Interphase barrier
- 25 Plug-in base
- 26 Draw-out base
- 27 DIN rail adaptor
- 28 Plug and pull safety device

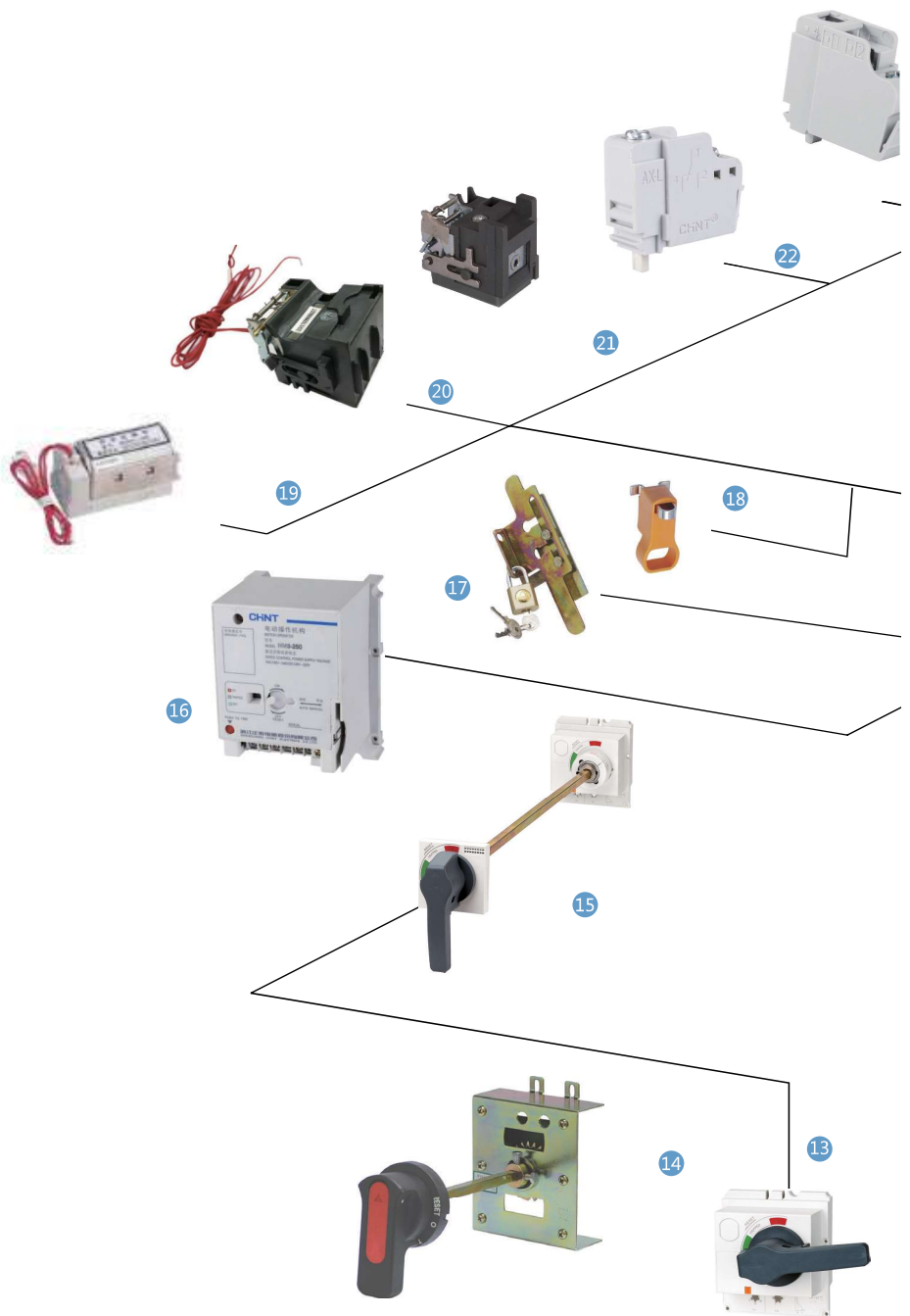

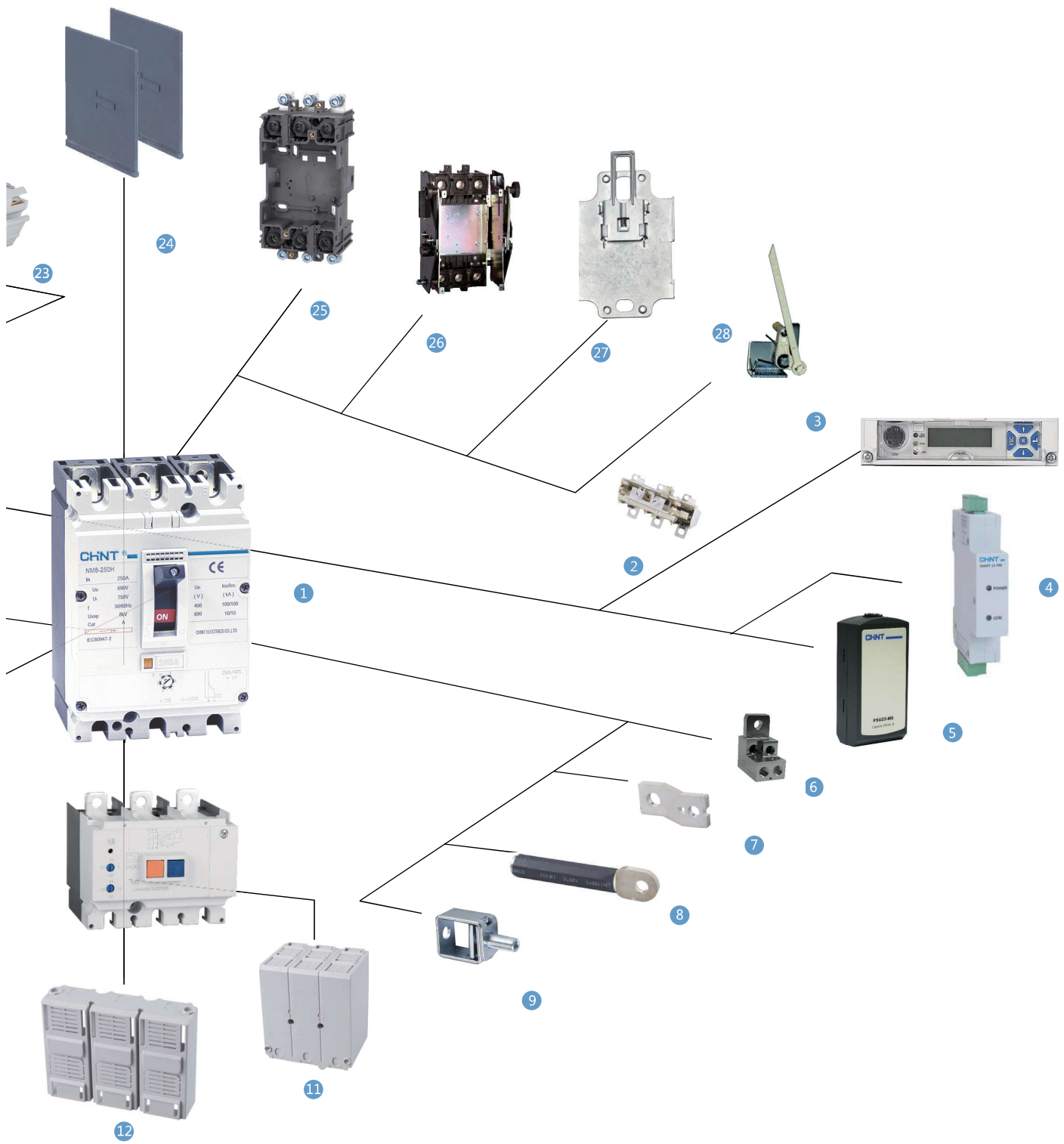

Contents

1. General.....	01
2. Operating conditions	01
3. Type designation	02
4. Technical data.....	04
5. Release.....	10
6. Tripping curve	13
7. Mounting of circuit breaker.....	20
8. Overall and Mounting Dimensions	21
9. Accessories characteristics and installation	49
10. Technical Supplement	71
11. Ordering notice	80



1. General

NM8N series moulded case circuit breaker is suitable for the circuit of AC 50/60Hz, with rated voltage AC690V and below, DC system rated voltage DC1000V and below, and rated current of 16A and 1600A. It can protect circuits and electric equipment against overload, short circuit or undervoltage, and can also provide protection of overload, short circuit and under voltage for infrequent start of motor.

Products have functions of power distribution protection, motor protection, residual current protection and isolation.

The circuit breaker can be installed vertically, installed horizontally and can also enter the line from the bottom.

Standards compliant:

IEC 60947-1 general rules for low-voltage switchgear and control equipment;
 IEC 60947-2 low-voltage switchgear and control equipment circuit breakers;
 IEC 60947-3 low-voltage switchgear and control equipment switches, disconnectors and fuse combination appliances;
 IEC 60947-4-1 Electromechanical contactors and motor starters (including motor protectors) for low voltage switchgear and control equipment

2. Operating conditions

2.1 Temperature:

Operating and storage temperature is $-40^{\circ}\text{C} \sim +70^{\circ}\text{C}$; the average value within 24 hours does not exceed $+35^{\circ}\text{C}$; when the ambient temperature is $-40^{\circ}\text{C} \sim +70^{\circ}\text{C}$, users need to consider derating or temperature compensation whose details can be referred to in Page

2.2 Altitude: $\leq 2000\text{m}$;

2.3 Pollution grade: Grade 3;

2.4 IP grade: IP40

2.5 Air conditions:

At mounting site, relative humidity not exceed 50% at the max temperature of $+40^{\circ}\text{C}$, higher relative humidity is allowable under lower temperature. For example, RH could be 90% at $+20^{\circ}\text{C}$, special measures should be taken to occurrence of dews.

3. Type designation

3.1 NM8N Moulded Case Circuit Breaker and Switch Disconnecter



N M 8 N □ - □ □ □ □ □ □ □ □

Special application

Poles:

1P: 1-pole

2P: 2-pole

3P: 3-pole

4B: 4-pole, there is no over-current protection at pole N and N-pole operates with other three poles

4C: 4-pole, there is over-current protection at pole N and N-pole operates with other three poles

Rated current

125 : 16-20-25-32-40-50-63-80-100-125

250 : 32-63-100-125-160-180-200-225-250

400 : 250-315-350-400

630 : 400-500-630

800 : 500-630-700-800

1600 : 800-1000-1250-1600

Release type code

TM: Thermal-magnetic type

EN: Basic electronic type for power distribution

EM: Standard electronic type for power distribution

M: Magnetic type for motor protection

ENM: Basic electronic type for motor protection

EMM: Standard electronic type for motor protection

Blank: Switch disconnector type

Breaking capacity code: B, C, S, Q, H, R
(Switch disconnector type has no code)

Frame size rated current:

125: 125A; 250: 250A; 400: 400A

630: 630A; 800: 800A; 1600: 1600A

DC: DC MCCB

Blank: AC MCCB

SD: Switch disconnector

Design code

Design sequence number

MCCB

Company code



3.2 NM8NL Residual Current

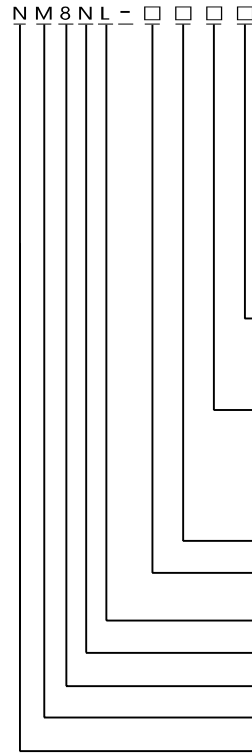

- Rated residual current code:
 - RCD1: 0.03-0.1-0.3-1A adjustable (Applicable to the frame size of 125-250-400-630)
 - RCD2: 0.05-0.2-0.5-2A adjustable (Applicable to the frame size of 125-250)
 - RCD3: 0.05-0.2-0.5-1A adjustable (Applicable to the frame size of 400-630)
 - RCD4: 0.1-0.3-1-2A adjustable (Applicable to the frame size of 400-630)
- Rated residual current type:
 - Default: AC type, A: A type
- Pole code:
 - 3P: 3-pole
 - 4P: 4-pole
- Frame size rated current:
 - 125: 125A; 250: 250A; 400: 400A; 630: 630A
- Residual current code
- Design code
- Design sequence number
- MCCB
- Company code

4. Technical data

NM8N Moulded Case Circuit Breaker		125	250								
Rated operating current In (A), 40 °C	Magnetic type	16-20-25-32-40-50-63-80-100-125									
	Thermal-magnetic type	16-20-25-32-40-50-63-80-100-125									
	Electronic type	—									
Electric characteristics											
Rated insulation voltage Ui (V)		1000									
Rated impulse withstand voltage (kV)		8									
Rated operational voltage Ue(V),AC 50/60Hz		380/400/415,440,500,660/690									
Breaking capacity code		C	S	Q	H	R	C	S	Q	H	R
Number of poles	1P	■	■	—	—	—	■	■	—	—	—
	2P	■	■	■	■	■	■	■	■	■	■
	3P	■	■	■	■	■	■	■	■	■	■
	4P	■	■	■	■	■	■	■	■	■	■
Rated ultimate short-circuit breaking capacity Icu(kA)	AC220/230/240V ¹⁾	36	50	—	—	—	36	50	—	—	—
	AC380/400/415V	36	50	70	100	150	36	50	70	100	150
	AC440V	36	50	70	100	100	36	50	70	100	100
	AC500V	25	40	40	50	50	25	40	40	50	50
	AC660/690V	6	8	8	10	10	6	8	8	10	10
Rated service breaking capacity Ics(kA)	AC220/230/240V ¹⁾	36	50	—	—	—	36	50	—	—	—
	AC380/400/415V	36	50	70	100	150	36	50	70	100	150
	AC440V	36	50	70	100	100	36	50	70	100	100
	AC500V	25	40	40	50	50	25	40	40	50	50
	AC660/690V	6	8	8	10	10	6	8	8	10	10
Rated short-time withstand current Icw(kA,1s)		—			1(32A,63A);2(100A,160A);3(250A)						
Standard		IEC/EN 60947-2									
Utilization category		A									
Ambient temperature		-40°C ~ +70°C ²⁾									
Safety of insulation		■									
Arcing distance		0									
Mechanical life (CO recycle)	Maintenance free	15000									
Electrical life (CO recycle)	AC415V,In	8000									
	AC690V,In	2000									
Release units											
Distribution protection	TM	■									
	EN	—									
	EM	—									
Motor protection	M	■									
	ENM	—									
	EMM	—									
Mounting and connection											
Fixed	Front connection	■									
	Rear connection	■									
Plug-in ³⁾	Front connection	■									
	Rear connection	■									
Draw-out ³⁾	Front connection	—									
	Rear connection	—									
DIN rail	Front connection	■									
Dimension											
Dimension (mm) W×H×D	Width (1P/2P/3P/4P)	35/62/90/120									
	Height	140									
	Depth	78.5									
Weight											
	1P	0.5									
	2P	0.83									
	3P	1.19									
Weight(kg)/Fixed	4P	1.55									
		2.5(TM/M) ; 2.65(EN/EM)									

Note : ¹⁾ For 1 pole product only ;

²⁾ The operating temperature of basic (dial code) electronic type is -35° C~+70° C, and the operating temperature of standard (liquid crystal) electronic type is -25° C~+70° C;

³⁾ For 3/4 pole product only ;

⁴⁾ The data in "0" is for motor type.



400		630					800					1600					
250-315-350-400		400-500					500-630-700-800					—					
250-315-350-400		400-500					500-630-700-800					800-1000-1250-1600					
250-400		400-630					630-800					800-1000-1250-1600					
1000		1000					1000					1000					
12		12					12					8					
380/400/415,440,500,660/690		380/400/415,440,500,660/690					380/400/415,440,500,660/690					380/400/415,440,500,660/690					
C	S	Q	H	R	C	S	Q	H	R	C	S	Q	H	R	S	Q	H
—	—	—	—	—	—	—	—	—	—	—	—	—	—	—	—	—	—
■	■	■	■	■	■	■	■	■	■	■	■	■	■	■	■	■	■
■	■	■	■	■	■	■	■	■	■	■	■	■	■	■	■	■	■
—	—	—	—	—	—	—	—	—	—	—	—	—	—	—	—	—	—
36	50	70	100	150	36	50	70	100	150	36	50	70	100	150	50	70	100
36	50	70	100	100	36	50	70	100	100	36	50	70	100	100	50	65	—
25	40	40	50	50	25	40	40	50	50	25	40	40	50	100	40	50	—
10	12	12	15	15	10	12	12	15	15	12	15	15	20	30	30	30	30
—	—	—	—	—	—	—	—	—	—	—	—	—	—	—	—	—	—
36	50	70	100	150	36	50	70	100	150	36	50	70	100	150	50	70	70
36	50	70	100	100	36	50	70	100	100	36	50	70	100	100	40	50	—
25	40	40	50	50	25	40	40	50	50	25	40	40	50	100	30	40	—
10	12	12	15	15	10	12	12	15	15	12	15	15	15	15	30	30	30
5					5(400A);8(630A)					10					20		
IEC/EN 60947-2																	
A(Thermal-magnetic)/B(Electronic)					A(Thermal-magnetic)/B(Electronic)					A(Thermal-magnetic)/B(Electronic)					A(Thermal-magnetic)/B(Electronic)		
-40°C ~ +70°C ²⁾																	
■					■					■					■		
0					0					0					0		
15000					15000					10000					6000		
4000					4000(400A)/3000(630A)					2000					1000		
1500					1500					1000					1000		
■					■					■					■		
■					■					■					■		
■					■					■					■		
■					■					■					■		
■					■					■					■		
■					■					■					■		
■					■					■					■		
—					—					—					—		
■					■					■					■		
■					■					■					■		
■					■					■					■		
■					■					■					■		
■					■					■					■		
—					—					—					—		
140/185					140/185					195/260					210/280		
255					255					300					286		
113					113					133					167 (195) ⁴⁾		
—					—					—					—		
—					—					—					—		
5.2(TM/M) ; 5.8(EN/EM)					5.5(TM/M) ; 6.0(EN/EM)					10.5(TM/M) ; 10.5(EN/EM)					13.5(16) ⁴⁾		
6.7(TM/M) ; 7.8(EN/EM)					7.0(TM/M) ; 8.0(EN/EM)					13.5(TM/M) ; 13.5(EN/EM)					17.5(20) ⁴⁾		

NM8N DC Moulded Case Circuit Breaker		125	250					250				
Rated operating current In (A), 40 °C		16-20-25-32-40-50-63-80-100-125					125-160-180-200-225-250					
Electric characteristics												
Rated insulation voltage Ui (V)		1000					1000					
Rated impulse withstand voltage Uimp (kV)		8					8					
Rated operational voltage Ue(V),DC		250 , 500 , 750 , 1000					250 , 500 , 750 , 1000					
Breaking capacity code		B	C	S	Q	H	B	C	S	Q	H	
Number of poles	1P	■	■	■	—	—	■	■	■	—	—	
	2P	■	■	■	■	■	■	■	■	■	■	
	3P	■	■	■	■	■	■	■	■	■	■	
	4P	■	■	■	■	■	■	■	■	■	■	
Rated ultimate short-circuit breaking capacity Icu(kA)	DC250V 1P	25	36	50	—	—	25	36	50	—	—	
	DC500V 2P in series	25	36	50	70	100	25	36	50	70	100	
	DC750V 3P in series	25	36	50	70	100	25	36	50	70	100	
	DC1000V 4P in series	25	36	50	70	100	25	36	50	70	100	
Rated service breaking capacity Ics(kA)	DC250V 1P	25	36	50	—	—	25	36	50	—	—	
	DC500V 2P in series	25	36	50	70	100	25	36	50	70	100	
	DC750V 3P in series	25	36	50	70	100	25	36	50	70	100	
	DC1000V 4P in series	25	36	50	70	100	25	36	50	70	100	
Standard		IEC/EN 60947-2										
Utilization category		A					A					
Ambient temperature		-40°C ~+70°C										
Safety of insulation		■					■					
Arcing distance		0					0					
Mechanical life (CO recycle)	Maintenance free	15000					15000					
Electrical life (CO recycle)	DC1000V,In	2000					1500					
Release units												
Distribution protection	TM	■					■					
Mounting and connection												
Fixed	Front connection	■					■					
	Rear connection	■					■					
Plug-in ¹⁾	Front connection	■					■					
	Rear connection	■					■					
Draw-out ¹⁾	Front connection	—					—					
	Rear connection	—					—					
DIN rail	Front connection	■					■					
Dimension												
Dimension (mm) W × H × D	Width (1P/2P/3P/4P)	35/62/90/120					40/70/105/140					
	Height	140					157					
	Depth	78.5					88.7					
Weight												
Weight(kg)/Fixed	1P	0.5					0.75					
	2P	0.83					1.3					
	3P	1.19					1.85					
	4P	1.55					2.5					

Note: ¹⁾ For 3/4 pole product only.



400		630					800					1600				
250-315-350-400		400-500					500-630-700-800					800-1000-1250-1600				
1000		1000					1250					1000				
12		12					12					8				
750, 1000		750, 1000					750, 1000					750, 1000				
B	C	S	Q	H	B	C	S	Q	H	B	C	S	Q	H	B	C
—	—	—	—	—	—	—	—	—	—	—	—	—	—	—	—	—
—	—	—	—	—	—	—	—	—	—	—	—	—	—	—	—	—
■	■	■	■	■	■	■	■	■	■	■	■	■	■	■	■	■
■	■	■	■	■	■	■	■	■	■	■	■	■	■	■	■	■
—	—	—	—	—	—	—	—	—	—	—	—	—	—	—	—	—
—	—	—	—	—	—	—	—	—	—	—	—	—	—	—	—	—
25	36	50	70	100	25	36	50	70	100	25	36	50	70	100	25	36
25	36	50	70	100	25	36	50	70	100	25	36	50	70	100	25	36
—	—	—	—	—	—	—	—	—	—	—	—	—	—	—	—	—
—	—	—	—	—	—	—	—	—	—	—	—	—	—	—	—	—
25	36	50	70	100	25	36	50	70	100	25	36	50	70	100	25	36
25	36	50	70	100	25	36	50	70	100	25	36	50	70	100	25	36
IEC/EN 60947-2																
A		A					A					A				
-40°C ~+70°C																
■		■					■					■				
0		0					0					0				
15000		15000					10000					6000				
1500		1500					1000					1000				
■		■					■					■				
■		■					—					■				
■		■					■					—				
■		■					—					—				
■		■					—					—				
■		■					■					—				
—		—					—					—				
140/185		140/185					195/260					210/280				
255		255					300					286				
113		113					133					167				
—		—					—					—				
—		—					—					—				
5.2		5.5					10.3					13.5				
6.7		7					13.5					17.5				

NM8NL Residual Current protection module		125	250	400	630
Rated operating current I_n (A), 40 °C		125	250	400	630
Number of poles		3P、4P	3P、4P	3P、4P	3P、4P
Electric characteristics					
Rated insulation voltage U_i (V)		1000	1000	1000	1000
Rated impulse withstand voltage U_{imp} (kV)		88		12	12
Rated operational voltage U_e (V),AC 50/60Hz		380/400/415、440	380/400/415、440	380/400/415、440	380/400/415、440
Rated current (A) of circuit breaker	TM	16-20-25-32-40-50-63-80-100-125	125-160-180-200-225-250	250-315-350-400A	400-500A
	EN	—	32-63-100-160-250	250-400	400-630
	EM	—	32-63-100-160-250	250-400	400-630
	M	16-20-25-32-40-50-63-80-100-125	125-160-180-200-225-250	250-315-350-400A	400-500A
	ENM	—	32-63-100-160-250	250-400	400-630
	EMM	—	32-63-100-160-250	250-400	400-630
Rated residual operating current $I_{\Delta n}$ (A)	RCD1 (Four-step adjustable)	0.03-0.1-0.3-1	0.03-0.1-0.3-1	0.03-0.1-0.3-1	0.03-0.1-0.3-1
	RCD2 (Four-step adjustable)	0.05-0.2-0.5-2	0.05-0.2-0.5-2	—	
	RCD3 (Four-step adjustable)	—		0.05-0.2-0.5-1	0.05-0.2-0.5-1
	RCD4 (Four-step adjustable)	—		0.1-0.3-1-2	0.1-0.3-1-2
Rated residual non-operating current $I_{\Delta no}$ (A)		0.5 $I_{\Delta n}$	0.5 $I_{\Delta n}$	0.5 $I_{\Delta n}$	0.5 $I_{\Delta n}$
Limit non-actuating time (ms) ¹⁾		Δt : 0-60-200-500			
Maximum breaking time (ms)	Total breaking time (adjustable)	100-300-500-1000	100-300-500-1000	100-300-500-1000	100-300-500-1000
Rated residual making and breaking capacity $I_{\Delta m}$ (kA)		0.25 I_{cu}	0.25 I_{cu}	0.25 I_{cu}	0.25 I_{cu}
Leakage alarm non-tripping function		<input type="checkbox"/>	<input type="checkbox"/>	<input type="checkbox"/>	<input type="checkbox"/>
Standard		IEC/EN 60947-2			
Residual current type		A/AC	A/AC	A/AC	A/AC
Safety of insulation		■	■	■	■
Ambient temperature		-25°C ~ +70°C			
Arcing distance		0000			
Dimension					
Dimension with circuit breaker (mm) W×H×D	Width (3P/4P)	90/120	105/140	140/185	140/185
	Height	205	232	355	355
	Depth	78.5	88	113	113
Weight					
Weight of residual current protection module (kg)	3P	0.43	0.84	1.98	1.98
	4P	0.51	1.08	2.69	2.69

Note : ¹⁾ When the residual operating current is set to 0.03A, the limit non-actuating time must be set to 0.



NM8NSD Switch Disconnecter		125			250			400		800		1600	
NM8NSD Switch Disconnecter Ith(A),40°C		125			250			400		800		1600	
Number of poles		2P	3P	4P	2P	3P	4P	3P	4P	3P	4P	3P	4P
Rated operational current Ie(A)		125			250			400		800		800-1000-1250-1600	
Rated operational voltage Ue(V)		690			690			690		690		415/690	
		AC (50/60Hz)			500 750 1000			500 750 1000		750 1000		750 1000	
		DC			500 750 1000			750 1000		750 1000		750 1500	
Rated insulation voltage Ui (V)		1000			1000			1000		1250		AC : 1000 DC : 1500	
Rated impulse withstand voltage Uimp (kV)		88						12		12		12	
Rated short-circuit making capacity Icm(kA)		3.2(AC)/2(DC)			5(AC)/3.2(DC)			8(AC)/5(DC)		14		40(AC)/19.2(DC)	
Rated short-time withstand current Icw(kA)		1s			3s			2		3.2		5	
		2			3.2			5		8/10		20	
Standard		IEC/EN 60947-3 , GB/T 14048.3											
Utilization category		AC-22A/AC-23A DC-22A/DC-23A			AC-22A/AC-23A DC-22A/DC-23A			AC-22A/AC-23A DC-22A/DC-23A		AC-22A/AC-23A DC-22A/DC-23A		AC-22A/AC-23A DC-22A/DC-22B	
Safety of insulation		■			■			■		■		■	
Ambient temperature		-40°C ~ +70°C											
Arcing distance		00						000					
Mechanical life (CO recycle)		Maintenance free			15000			15000		15000		10000	
		AC415V,In			8000			6000		4000		2000	
		AC690V,In			2000			1500		1500		1000	
		DC1000V,In			2000			1500		1500		1000	
Mounting and connection													
Fixed		Front connection			■			■		—		■	
		Rear connection			■			■		■		■	
Plug-in ¹⁾		Front connection			■			■		—			
		Rear connection			■			■		—			
Draw-out ¹⁾		Front connection			—			■		■		—	
		Rear connection			—			■		■		—	
DIN rail		Front connection			■			—					
Dimension													
Dimension(mm)		Width(2P/3P/4P)			62/90/120			70/105/140		140/185		195/260	
		Height			140			157		255		300	
		Depth			78.5			88		113		133	
												167 (195) ²⁾	
Weight													
Weight(kg)/Fixed		2P			0.81			1.1		—			
		3P			1.05			1.75		5		9.5	
		4P			1.5			2.4		5.5		12.5	
												13(15.5) ²⁾	
												17(19.5) ²⁾	

Note: ¹⁾ For 3/4 pole product only ;
²⁾ The data in "()" is for motor type



5 Release

5.1 Protection for power distribution

5.1.1 Thermo-magnetic type release TM

Thermo-magnetic release of NM8N-125, 250, 400, 630, 800 and 1600 breakers can be set to meet protection requirements

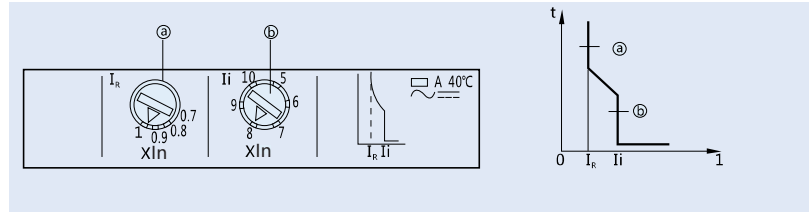

Thermo-magnetic release TM	125		250		400	630	800	1600
Number of poles	1P	2P/3P 4P	1P	2P/3P/4P	3P/4P	3P/4P	3P/4P	3P/4P
Rated current	16/20/25 32/40/50 63/80/100/125		125/160 180/200 225/250	125 180 200/225 250	250/315 350/400	400/500	500/630 700/800	800/1000 1250/1600
Over-load protection								
Setting current (A) $I_r = I_n \times$	1.0 Non-adjustable	0.7-0.8-0.9-1.0	1.0 Non-adjustable	0.7-0.8-0.9-1.0			0.8-0.9-1.0	
Short-circuit instantaneous protection								
Setting current (A) $I_i = I_n \times$	10		10	7-8-9-10-11-12	5-6-7-8-9-10			
Accuracy	±20%							
N-pole protection								
Setting current (A) $I_{IN} = I_n \times$	/	10	/	The same with the other three-phase poles.				
Accuracy	±20%							

5.1.2 Basic electronic type release for power distribution EN

EN electronic trip unit has three-stage protection of overload, short circuit short time-delay and short circuit instantaneous protection.



Electronic type EN		250	400	630	800	1600
Over-load long-time delay protection	Setting current $I_r = I_n \times$	0.4-0.5-0.6-0.7-0.8-0.9-0.95-1.0				
	$6I_r$, Tripping time T_r (s)	3-6-12-18, Accuracy ±10%				
Short circuit short-time delay protection	Setting current $I_{sd} = I_n \times$	1.5-2-3-4-6-8-10, OFF, Accuracy ±15%				
	Tripping time T_{sd} (s)	0.1-0.2-0.3-0.4, Accuracy ±20% or ±40ms(higher value will be selected)				
Short circuit instantaneous protection	Setting current $I_i = I_n \times$	2-3-4-6-8-10-12, OFF, Accuracy ±15%				
	Max. tripping time (ms)	60				
Neutral line protection	Setting current	$I_N = (0.5, 1) \times I_n$, OFF; $I_{sdN} = (1.5-2-3-4-6-8-10) I_N$				
	Tripping time (s)	$I_N = (2-3-4-6-8-10) I_N$				

- Overload protection and tripping time setting
—The current value I_r can be adjusted according to the user's needs. The tripping time T_r is at the status of $6I_r$.
- Short circuit short-time delay protection and trip time setting
—The current value I_{sd} can be adjusted according to the user's needs. Tripping time T_{sd} is the shortcircuit short time-delay tripping time, which can be adjusted according to user needs.
- Short circuit instantaneous protection characteristics setting
—The current value I_i can be adjusted according to the user's needs.
- Neutral line protection feature setting
The four-pole circuit breaker N-pole protection current value can be adjusted according to user needs. The N pole tripping time is the same with the other three-phase poles.

5.1.3 Standard electronic type release for power distribution EM

EM release has four-stage protection of overload, short circuit short-time delay, short circuit instantaneous protection and earth fault, with real-time current display, protection parameter

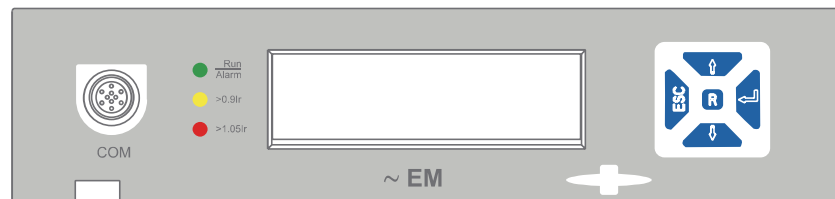



information display, fault information display and parameter setting function

Electronic type EM	250	400	630	800	1600
Over-load long-time delay protection	Setting current $I_r=I_n \times 6I_r$, Tripping time $T_r(s)$	0.4~1.0, Stepping1A 3~18, 1s, Accuracy $\pm 10\%$			
	Setting current $I_{sd}=I_n \times$	1.5~10, Stepping1A, OFF, Accuracy $\pm 15\%$			
Short circuit short-time delay protection	Tripping time $T_{sd}(s)$	0.1-0.2-0.3-0.4, Accuracy $\pm 20\%$ or $\pm 40ms$ (higher value will be selected)			
	Setting current $I_i=I_n \times$	1.5~12, Stepping1A, OFF, Accuracy $\pm 15\%$			
Short circuit instantaneous protection	Max. tripping time (ms)	60			
	Setting current $I_g=I_n \times$	0.4-0.5-0.6-0.7-0.8-0.9-1.0, OFF, Accuracy $\pm 15\%$			
Earth fault protection	Tripping time (s)	0.1-0.2-0.3-0.4, Accuracy $\pm 15\%$			
	Setting current	$I_{N1}=(0.5,1) \times I_n$; $I_{N2}=(1.5 \sim 10)I_n$; $I_{N3}=(1.5 \sim 12)I_n$, able to turn OFF			
Neutral line protection	Tripping time (s)	The same with the other three-phase poles.			

- Overload protection and tripping time setting
— Current setting value I_r , the user can adjust the range according to the \uparrow and \downarrow buttons on the panel, the range is $(0.4 \sim 1.0) I_n$, and the tripping time T_r is at the status of $6I_r$, which can be adjusted according to user needs.
- Short circuit short-time delay protection and tripping time setting
— The current setting value I_{sd} can be adjusted according to the user's needs, and the "OFF" indicates function can be turned off. Tripping time T_{sd} is the short-circuit short-time delay tripping time, which can be adjusted according to user needs.
- Short circuit instantaneous protection characteristics setting
— The current setting value I_i can be adjusted according to the user's needs, and the "OFF" indicates function can be turned off.
- Neutral line protection feature setting
— Neutral line protection of the four-pole circuit breaker (current setting value I_{N1}), the setting range is $0.5I_n$, $1I_n$ or OFF, which can be adjusted according to the user's needs. The "OFF" position indicates that the N pole has no protection function.
- Earth fault protection
Earth fault I_g can be adjusted according to user needs, where the "OFF" means the function can be turned off.

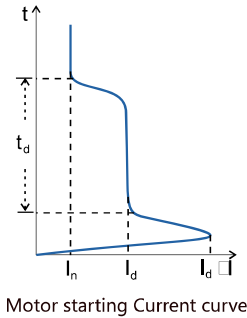

5.2 Protection for motor

5.2.1 Motor starting characteristics

At present, most of the motors use three-phase asynchronous induction motors, and a large part of them use the direct start mode, namely, the electric energy does not take artificial restriction measures, and directly feeds to start the motor, which is also called full-pressure start. When the asynchronous motor is directly started, a high starting current of 4 to 7 times of the rated current occurs. The reason why the asynchronous motor has a large starting current is that the motor has certain inertia, and the rotor speed cannot be immediately changed to the rated speed after starting. At this time, the relative rotational speed of the rotating magnetic field of the stator (synchronous speed of the motor, slightly higher than the rated speed) is large. The rotor winding cuts the stator magnetic field at a large speed to generate a large current; at the same time, the magnetic field generated by the large current of the rotor in turn induces the stator winding, so that the current also rapidly increases.

Startup parameter

Rated current (I_n): current value of the motor under rated operation

Starting current (I_d): The current when the motor starts, its magnitude varies with different conditions, the average value is $7.2 \times I_n$

Start peak current (I_p):

Transient current during the first two half-waves after the motor is powered on, typically $14 \times I_n$

Start-up time (t_d): generally $0.5 \sim 20s$, which refers to the time when the motor has starting current

Direct startup impact on the protection device

For circuit breakers with magnetic protection, if the conventional current of the magnetic trip unit is set incorrectly, the circuit breaker will mistake the start current of the motor for short-circuit current, causing the circuit breaker to malfunction. For the independent thermal relay, the heat generated by the large starting current during the motor starting phase will also cause the relay to trip. For the contactor, if the motor needs electric or regenerative braking, it needs to be able to be broken during the motor starting phase. It generally needs to derate, in order to avoid the malfunction of the protection device caused by the start current:

The inverse time characteristic curve of the independent thermal relay is required to be completely above the starting current.

The short-circuit current trip setting of the circuit breaker with magnetic protection should be greater than the peak starting current of the motor.

5.2.2 Protection solution

The NM8N Series offers start-up, control and protection solutions for two three-phase asynchronous motors:



Three-component solution

Electromagnetic protection circuit breaker + contactor + thermal relay

Among them, the electromagnetic protection circuit breaker is used for short circuit protection, the contactor is used for motor operation, and the thermal relay is used for overload, phase loss and phase unbalance protection.

1) Magnetic release M

The electromagnetic protection circuit breaker has a current range of 125~800A, an adjustable range of 9~14In and an accuracy of 20%. It is especially suitable for use in the classic three-component protection solution.

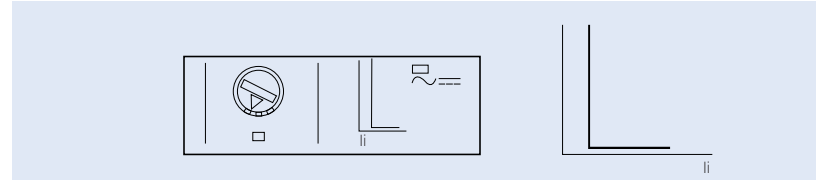

Magnetic M	125	250	400	630	800
Pole	3P/4P	3P/4P	3P/4P	3P/4P	3P/4P
Short circuit instantaneous protection					
Setting current (A) $I_i=I_n \times$	12	9-10-11-12-13-14			
Accuracy	±20%				
N pole protection					
Setting current (A) $I_{iN}=I_n \times$	12	The same with the other three-phase poles.			
Accuracy	±20%				

Two-component solution

Integrated protection electronic circuit breaker + contactor

In the two-component solution, there is no need to use the thermal relay, and the integrated protection electronic circuit breaker has the functions of overload, phase loss, phase unbalance protection and short circuit protection. The integrated protection electronic circuit breaker not only has high tripping precision, but also has reliable operation. The two-component solution consisting of contactors and the installation time can be saved without being affected by the ambient temperature.

2) Integrated protection: Basic electronic type release for motor protection ENM

The ENM electronic trip unit allows for tighter tolerance trip times, as detailed in the table below.

Electronic type ENM		250	400	630	800
Overload	Setting current $I_i=I_n \times$	0.4-0.5-0.6-0.7-0.8-0.9-1.0, OFF			
long-time delay protection	7.2I, Tripping time T_i (s)	4, 8, 16, Accuracy ±10%	48, 16, 24, Accuracy ±10%		
	Tripping level	5, 10, 20	5, 10, 20, 30		
Short circuit short-time delay protection	Setting current $I_{sd}=I_n \times$	5-6-8-9-10-11-12, OFF, Accuracy ±15%			
	Tripping time T_{sd} (ms)	100, Accuracy ±40			
Short circuit instantaneous protection	Setting current $I_i=I_n \times$	15 ¹⁾			
	Max. tripping time (ms)	60			
Phase unbalance/Phase failure I_{unbal}		30%-40%-50%-60%-70%-80%-90% (Phase failure)-OFF			
Max. trip time of phase imbalance (s)		4-6-8-10, Accuracy ±10%			
Tripping time of phase failure (s)		0.25, Accuracy ±20%			
Neutral line protection	Setting current	$I_{iN}=(0.5,1) \times I_{iN}$; OFF; $I_{sdN}=(5-6-8-9-10-11-12)I_{iN}$ $I_{iN}=15I_{iN}$, OFF			
	Tripping time	The same with the other three-phase poles			

Note: 1) Setting current $I_{sd} < I_i$ (within tolerance).

3) Integrated protection: Standard electronic type release for motor protection EMM

The EMM electronic release not only has the protection function of the ENM release, but also adds ground fault protection and stall protection. Moreover, it can also display real-time current, display protection parameter information, display fault information, and have parameter setting function.

Electronic type EMM		250	400	630	800
Overload	Protection current $I_i=I_n \times$	0.4~1.0, Stepping 1A, OFF			
long-time delay protection	7.2I, Tripping time T_i (s)	4, 8, 16, Accuracy ±10%	4, 8, 16, 24, Accuracy ±10%		
	Tripping level	5, 10, 20	5, 10, 20, 30		
Short circuit short-time delay protection	Protection current $I_{sd}=I_n \times$	4~12, Stepping 1A, OFF, Accuracy ±15%			
	Tripping time T_{sd} (ms)	100, Accuracy ±40			
Short circuit instantaneous protection	Protection current $I_i=I_n \times$	15 ¹⁾			
	Max. tripping time(ms)	60			
Earth fault protection	Protection current $I_g=I_n \times$	0.4-0.5-0.6-0.7-0.8-0.9-1.0, OFF, Accuracy ±15%			
	Tripping time (s)	0.1-0.2-0.3-0.4, Accuracy ±20% or 40ms(higher value will be selected)			
Phase unbalance/Phase failure I_{unbal}		30%-40%-50%-60%-70%-80%-90%(Phase failure)-OFF			
Max. trip time of phase imbalance (s)		4-6-8-10, Accuracy ±10%			
Tripping time of phase failure (s)		0.25, Accuracy ±20%			
Locked-rotor current I_{brm}		$(3 \sim 10)I_i$, Stepping 1A, OFF(Default), Accuracy ±15%			
Tripping time T_{brm} (s)		1~30, Step size 1s, Default 5, Accuracy ±10%			
Neutral line protection	Setting current	$I_{iN}=(0.5,1) \times I_{iN}$, OFF; $I_{sdN}=(4 \sim 12)I_{iN}$; $I_{iN}=15I_{iN}$, OFF			
	Tripping time	The same with the other three-phase poles.			

Note: ¹⁾ Setting current $I_{sd} < I_i$ (within tolerance).

6 Tripping curve

6.1 Thermal-magnetic type for power distribution



NM8N-125(16A,20A,25A,32A)

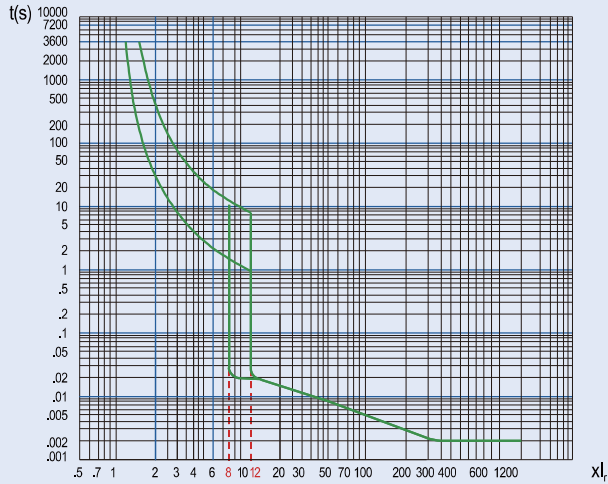

NM8N-125(40A,50A,63A)

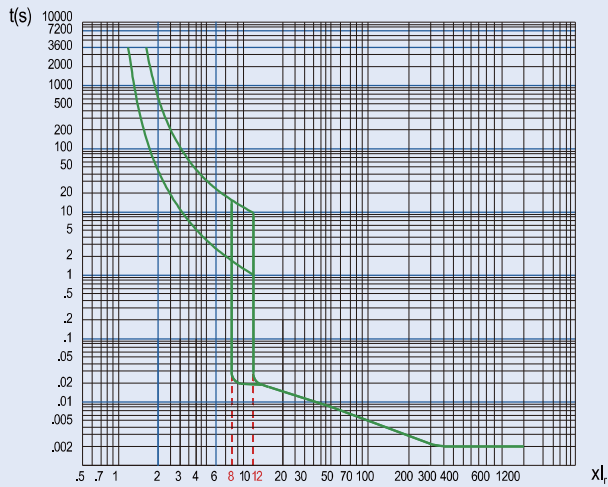

NM8N-125(80A,100A,125A)

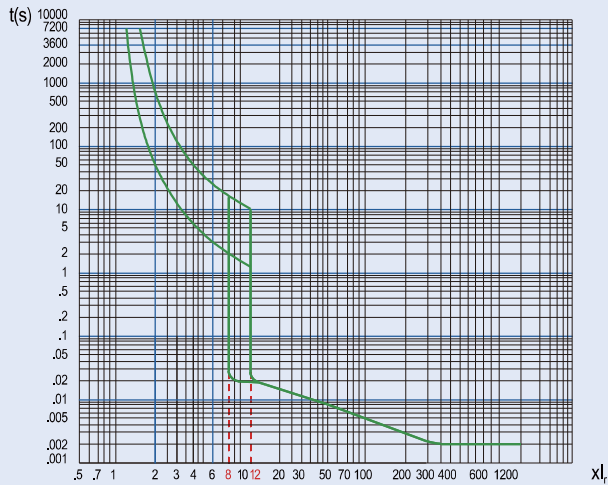

NM8N-125A/160A

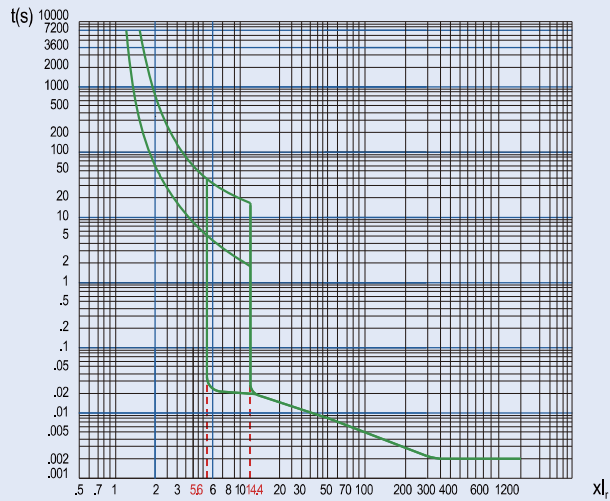

NM8N-250(180A)

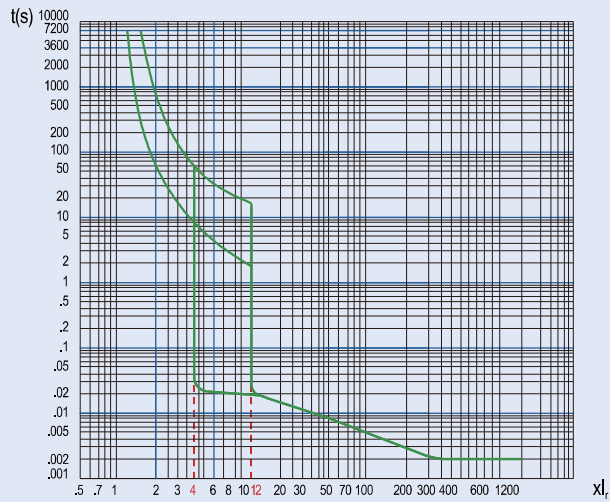

NM8N-250(200A,225A,250A)

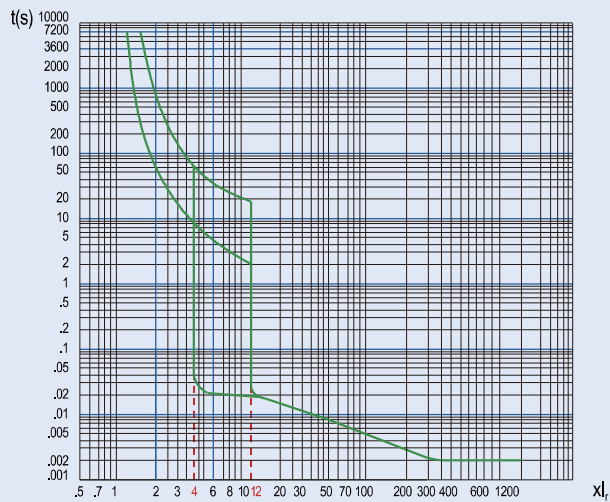



NM8N-400(250A~400A)

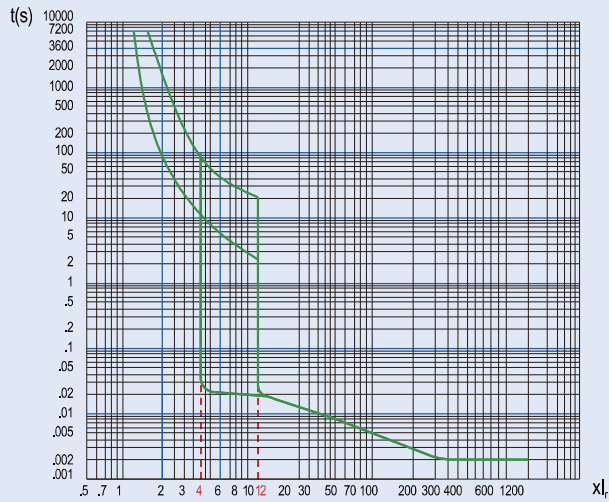

NM8N-630(400A~500A)

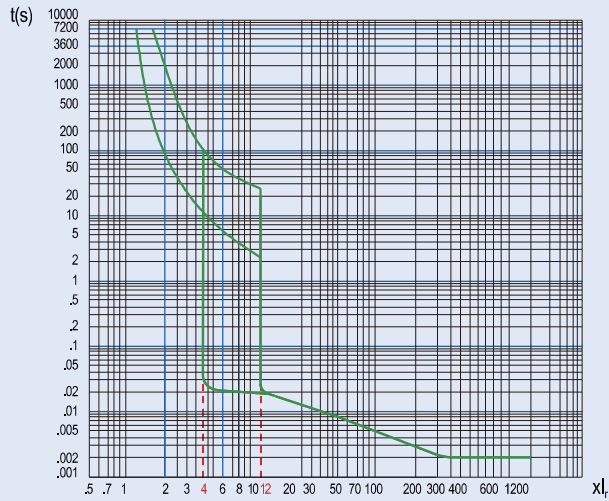

NM8N-800(500A~800A)

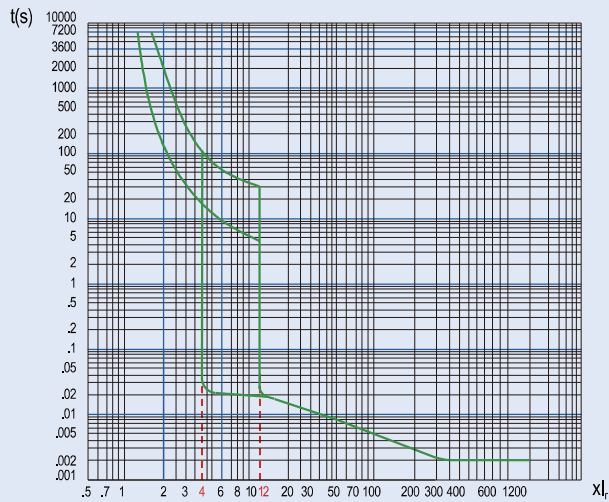

NM8N-1600(800A~1600A)

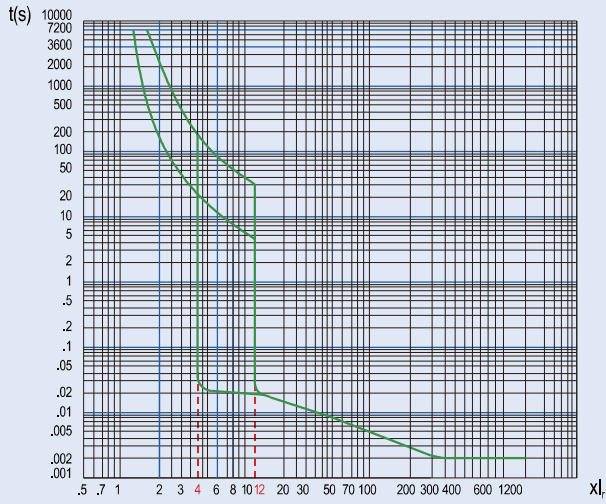

6.2 Magnetic type for motor protection

NM8N-125(16A~125A)

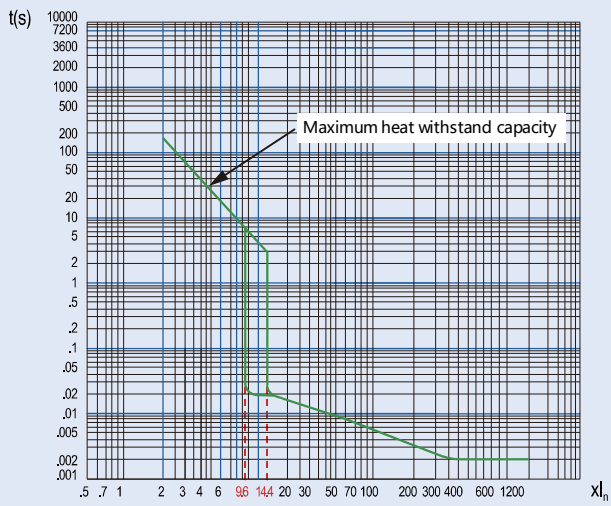

NM8N-250(125A~250A)

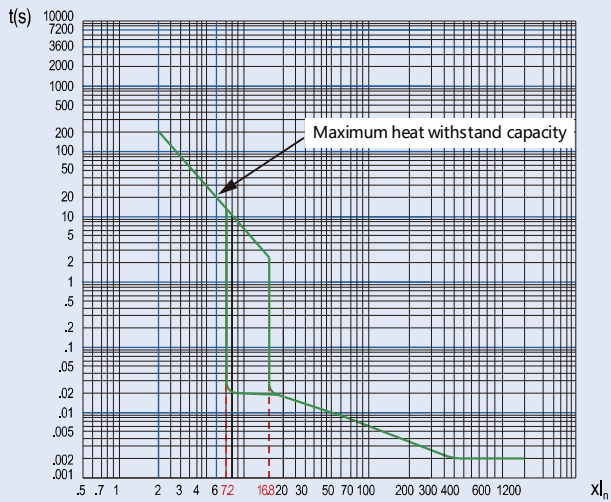



NM8N-400(250A~400A)

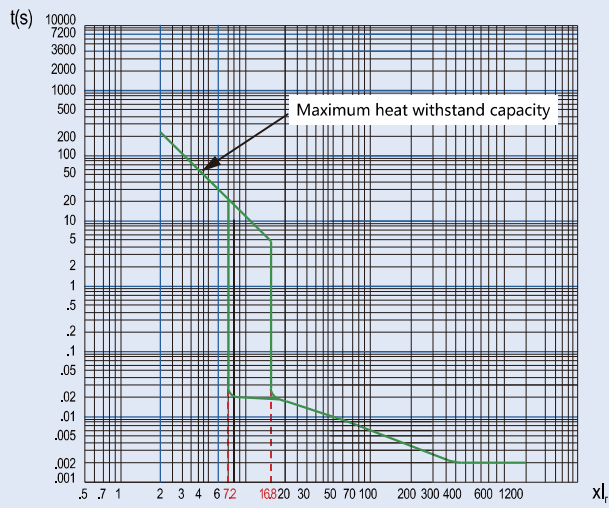

NM8N-630(400A~500A)

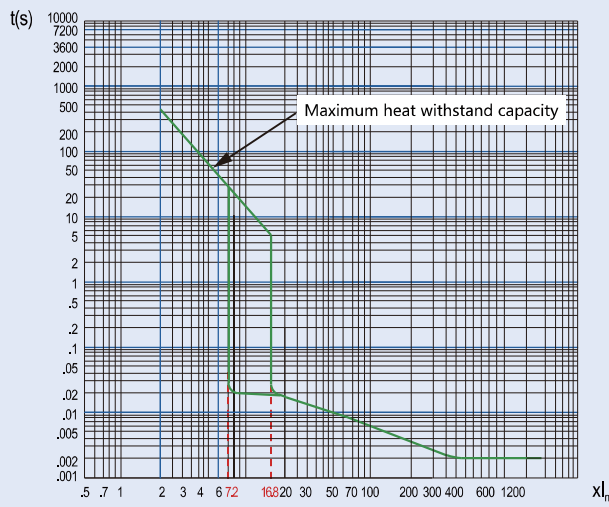

NM8N-800(500A~800A)

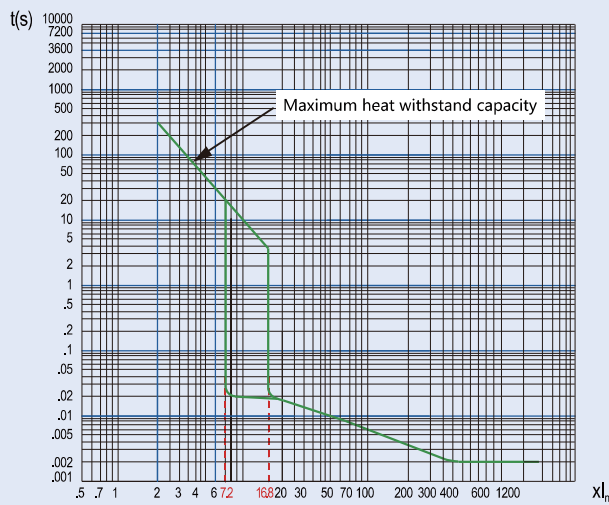

6.3 Electronic type for power distribution

EN Basic electronic type

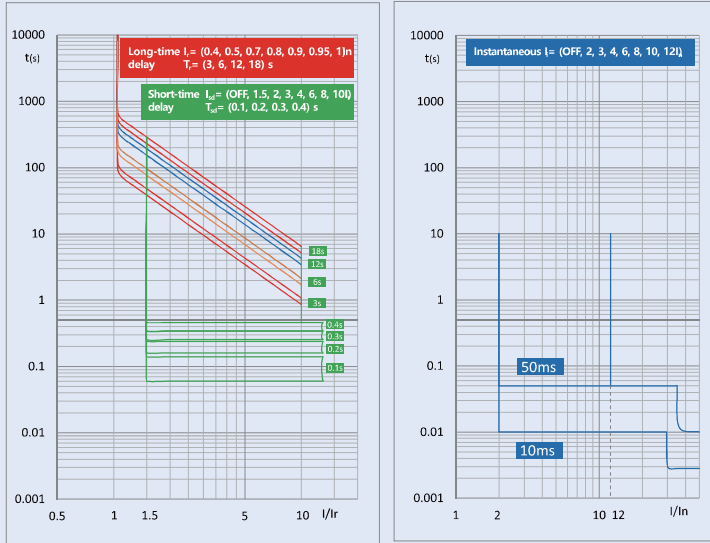

EM Standard electronic type

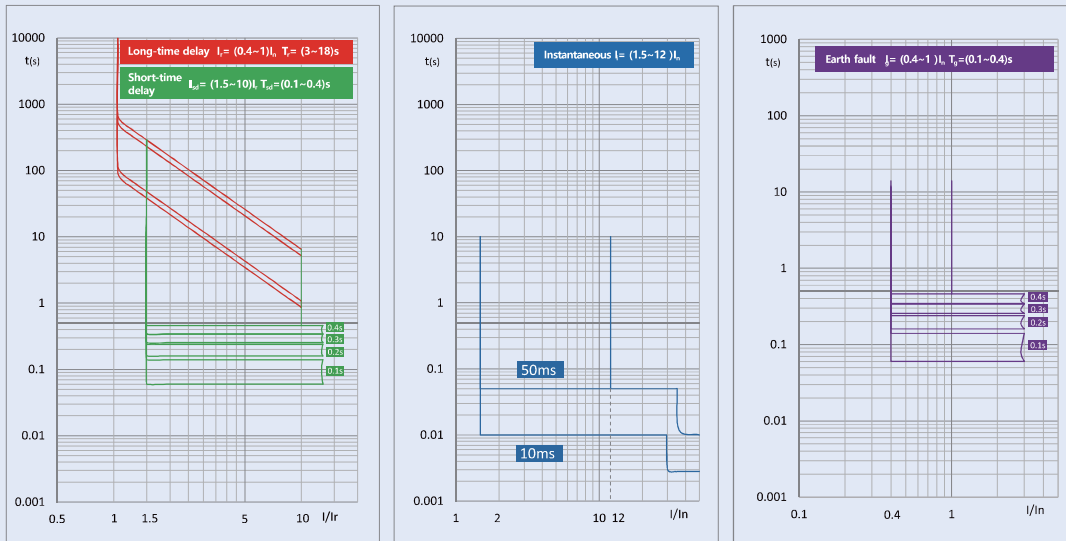

6.4 Electronic type for motor protection

ENM Basic electronic type

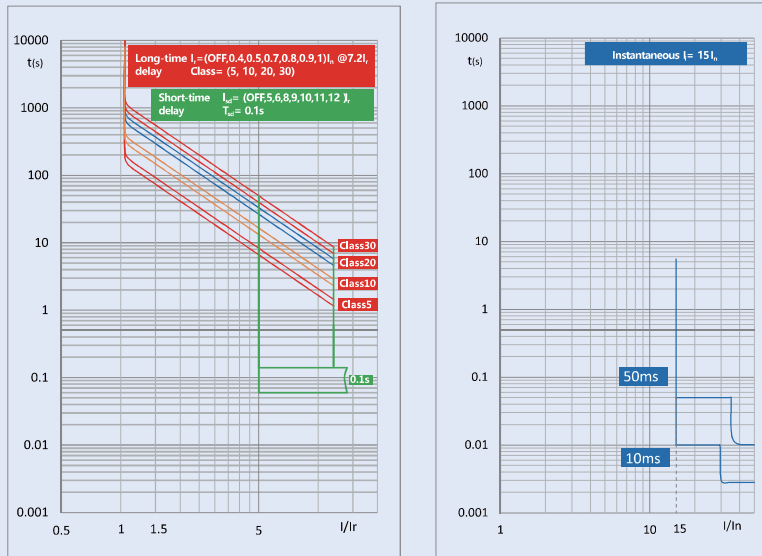

B

EMM Standard electronic type

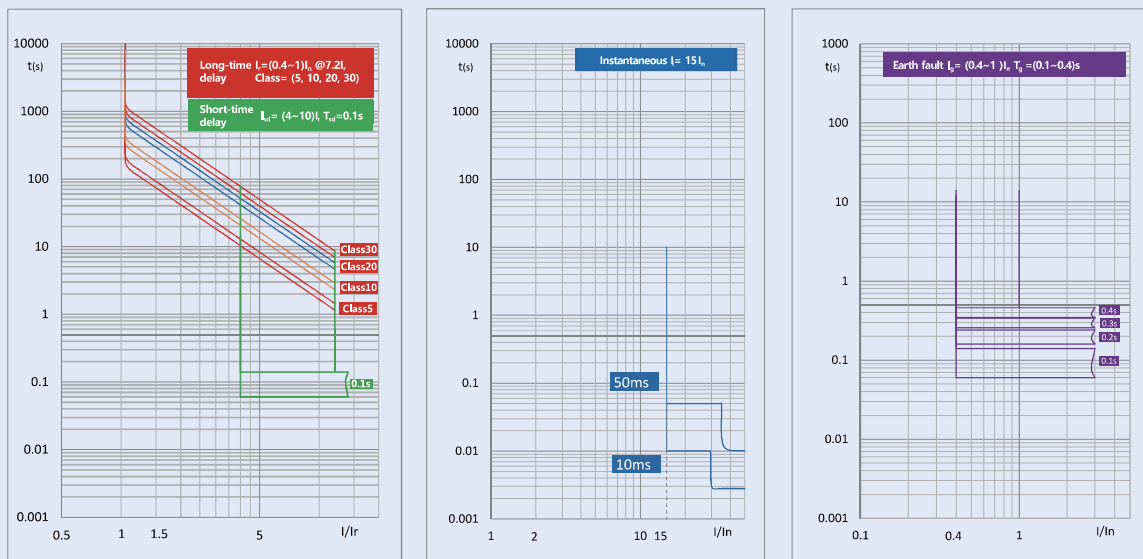

7 Mounting of circuit breaker

7.1 Modes of down-lead

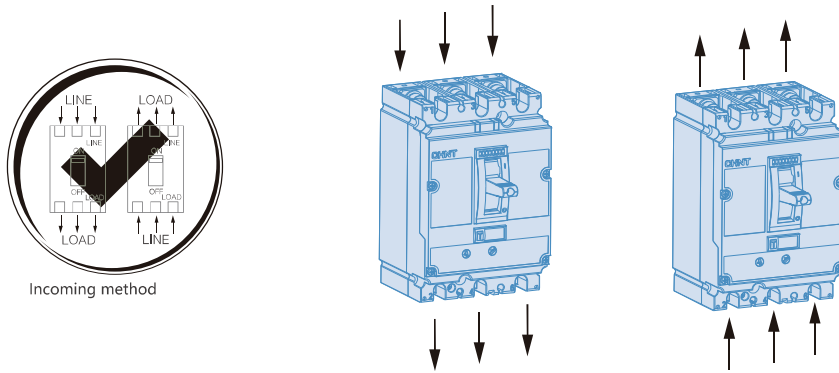

7.1 Modes of down-lead

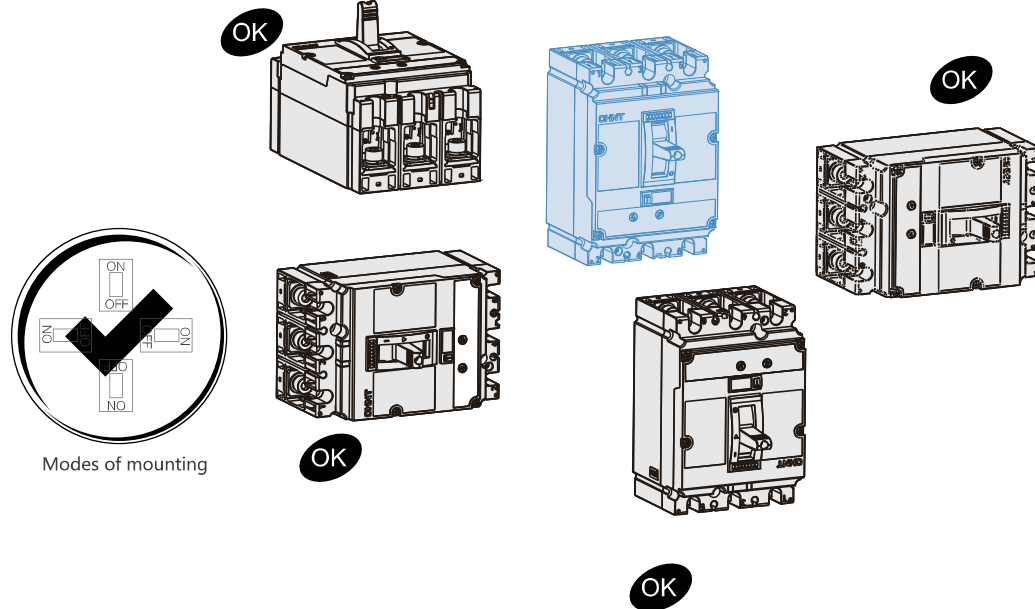

7.3 Safe distance

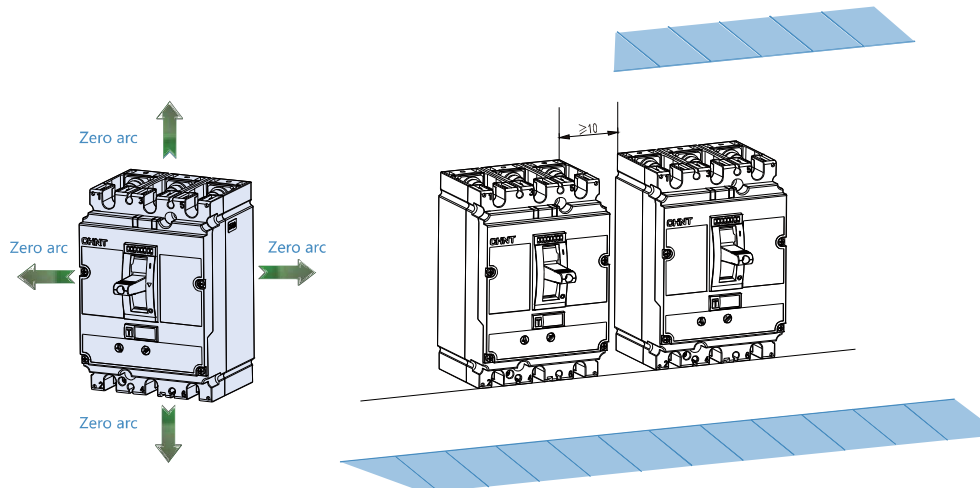

8 Overall and Mounting Dimensions

8.1 NM8N-125

NM8N-125 Front connection

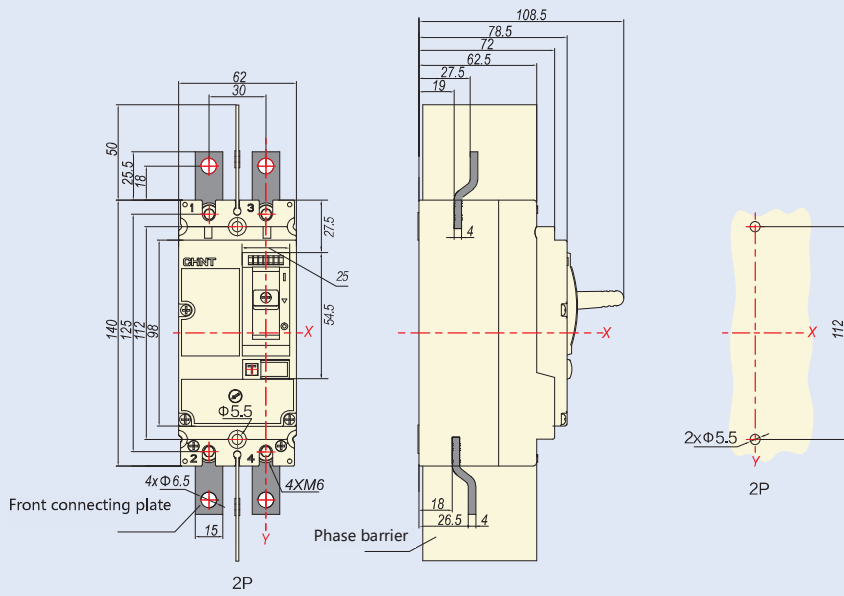
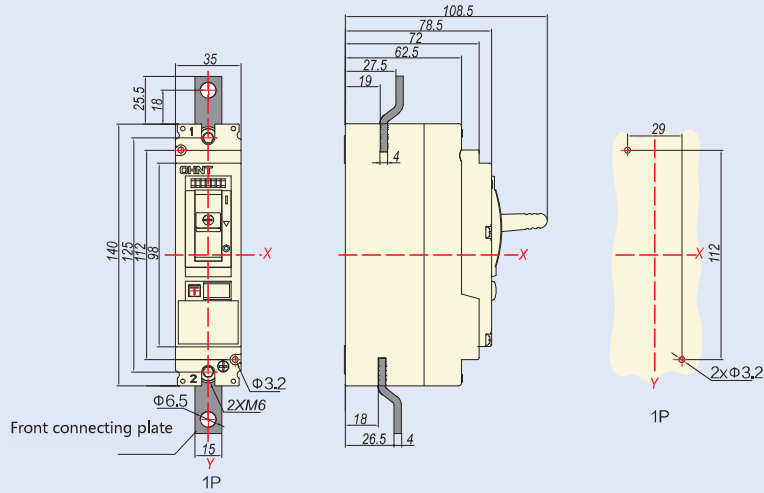

Unit:(mm)

NM8N-125 Front connection (3P/4P)

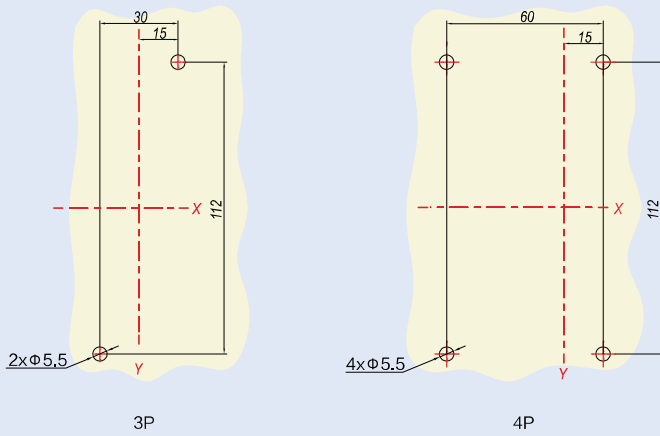
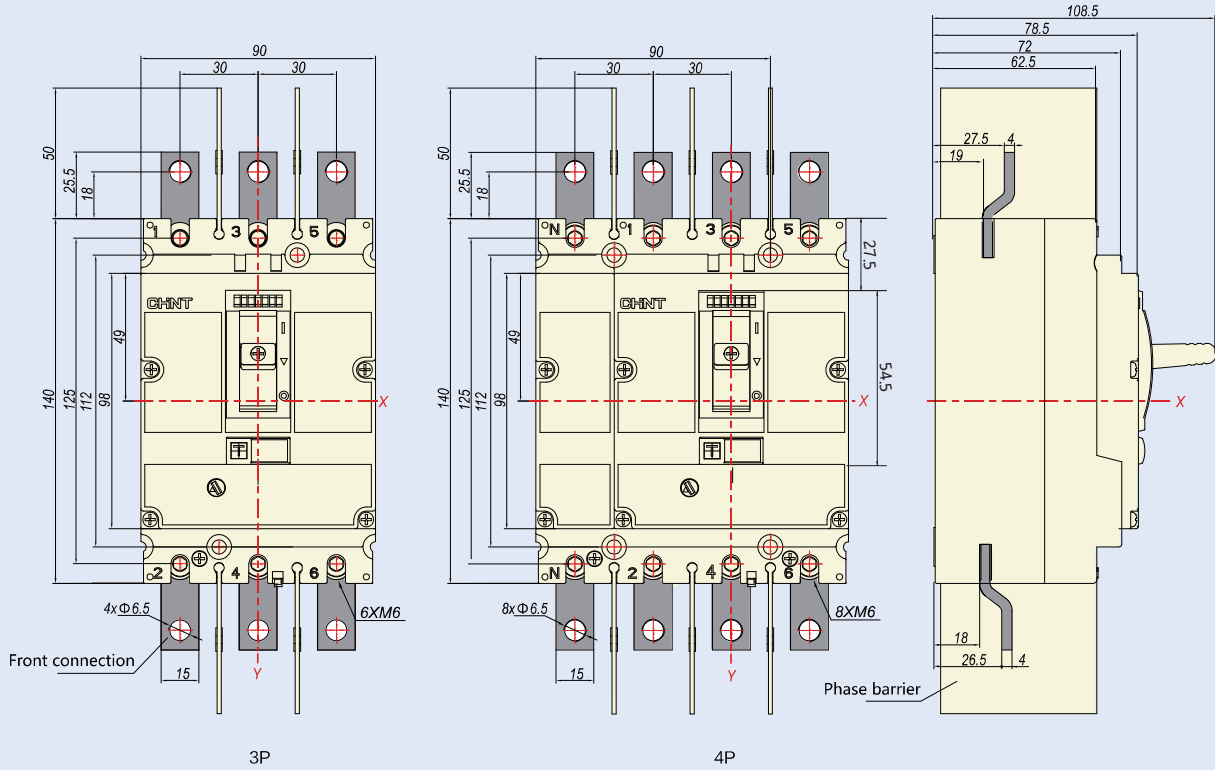

Unit:(mm)

NM8N-125 Rear connection (1P/2P)

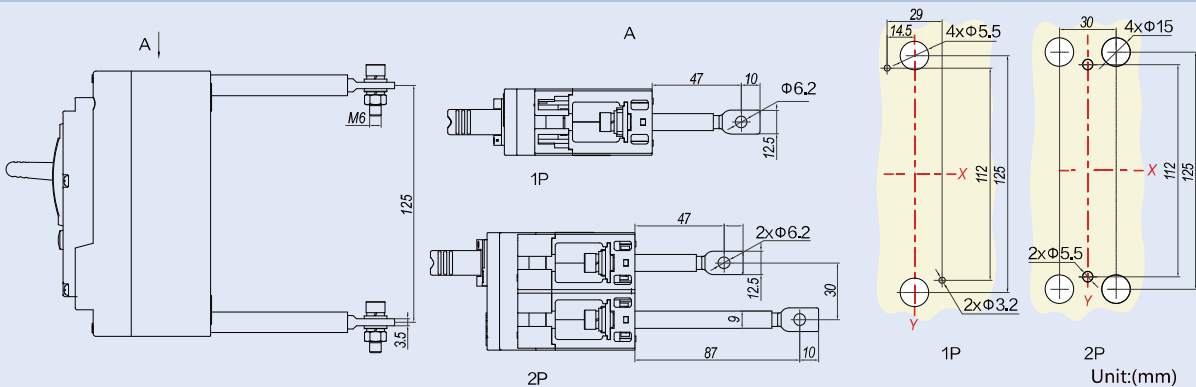

Unit:(mm)

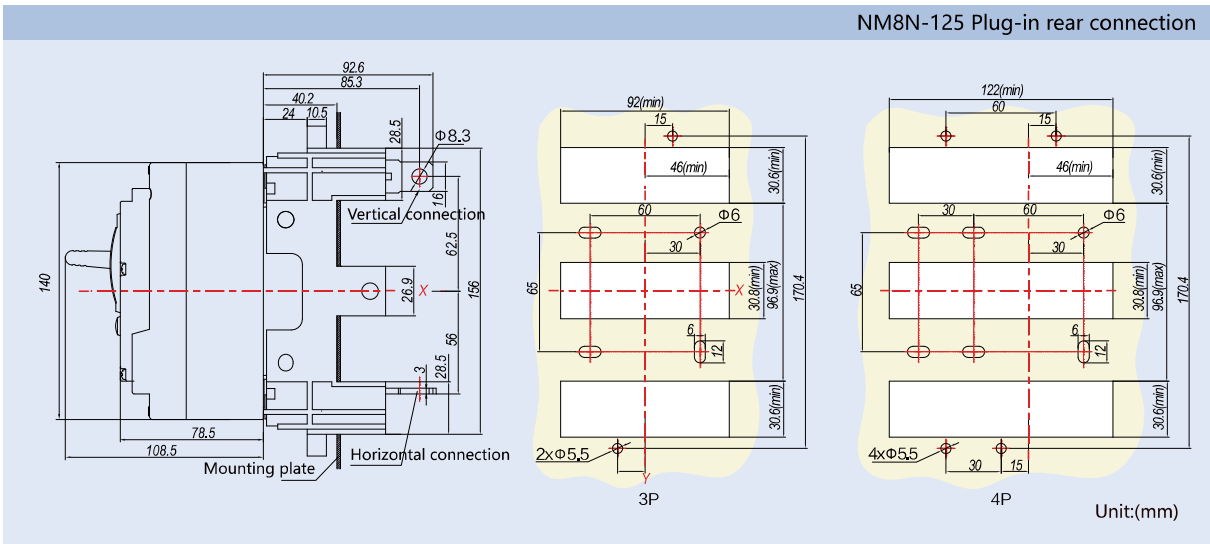
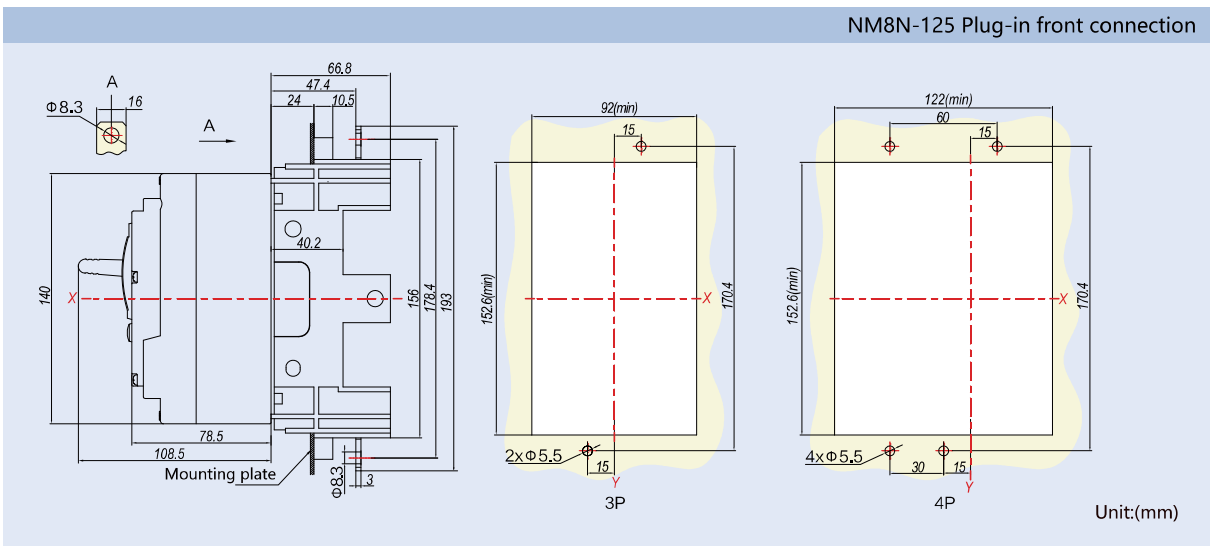
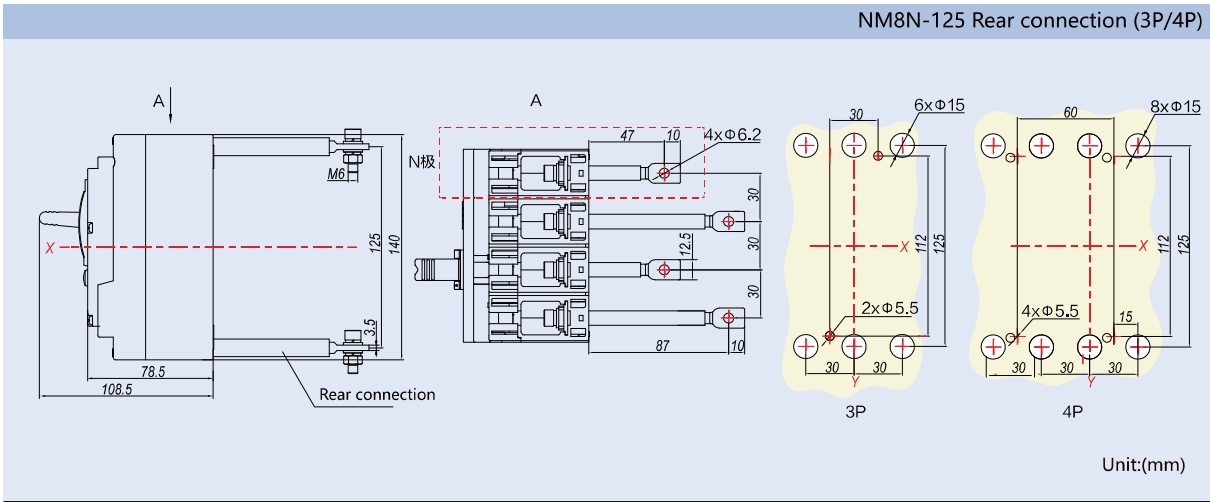

NM8N-125 DIN-rail mounting

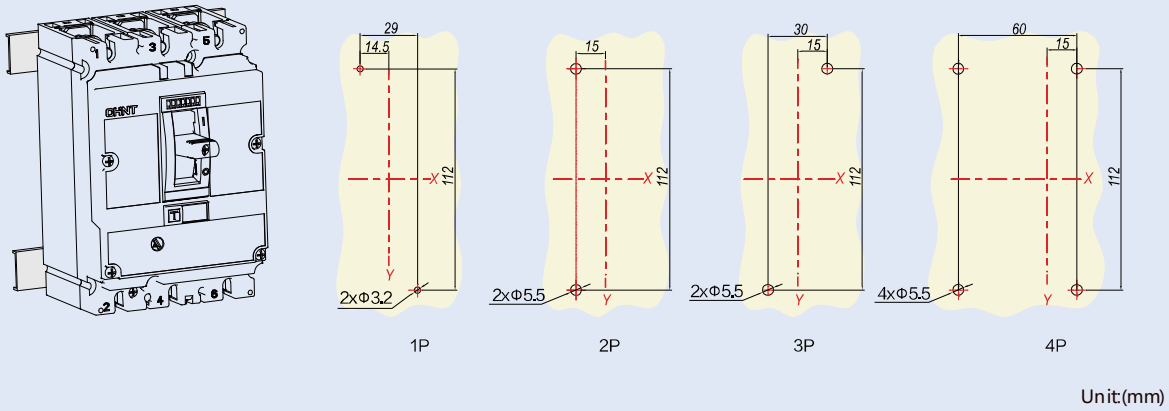

NM8N-125 DIN-rail mounting (DIN-rail adapter is needed)

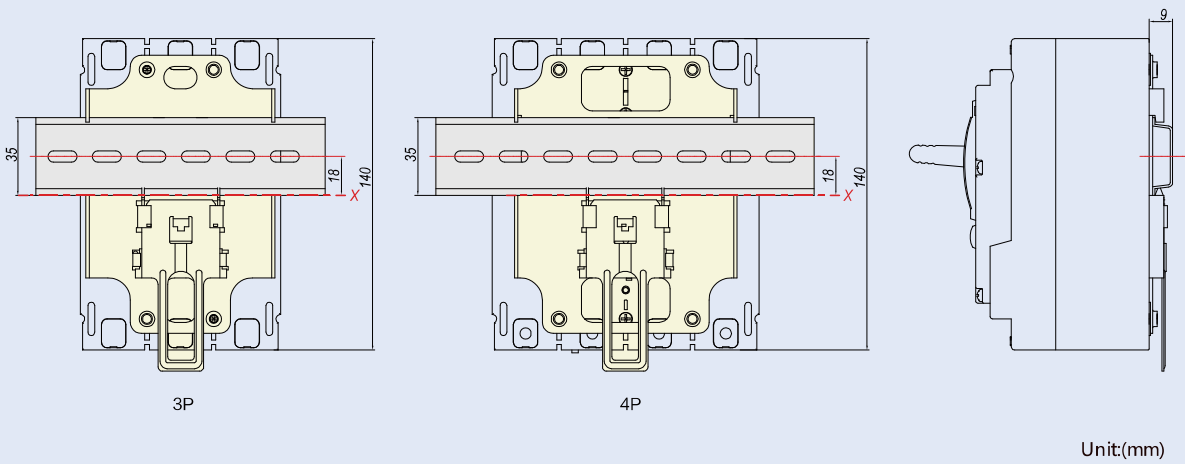

NM8N-125 Mechanical interlock

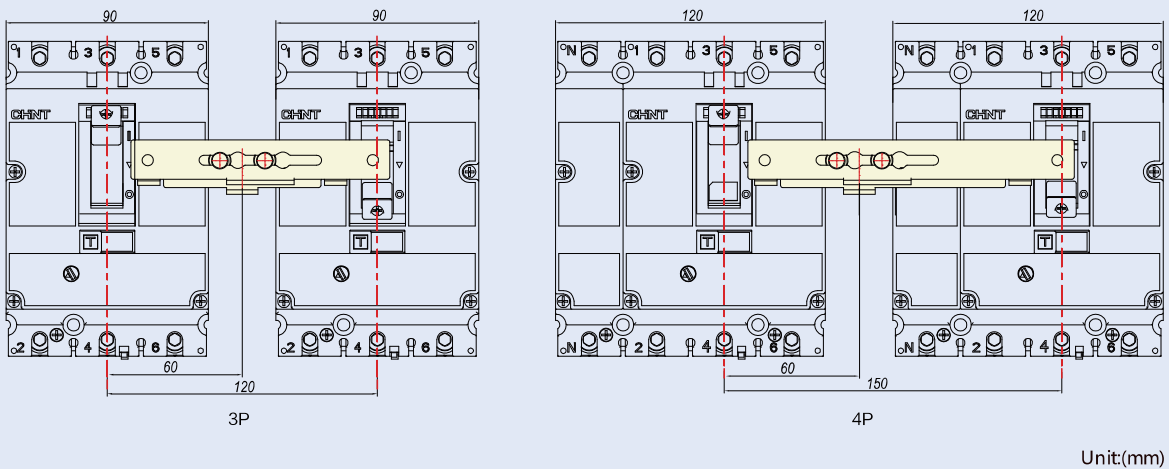

NM8N-125 Terminal cover

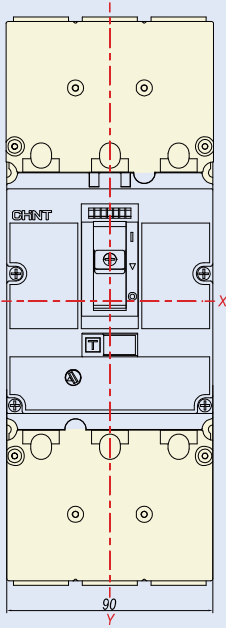

3P Long terminal cover

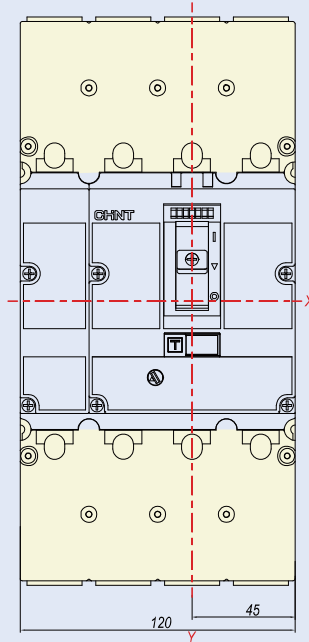

4P Long terminal cover

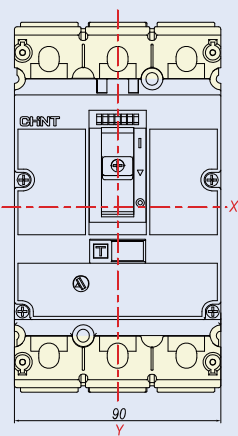
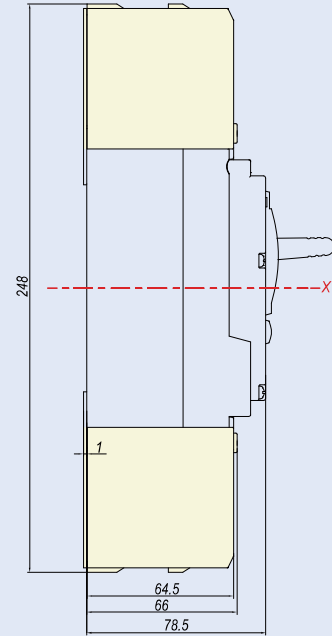

3P Short terminal cover

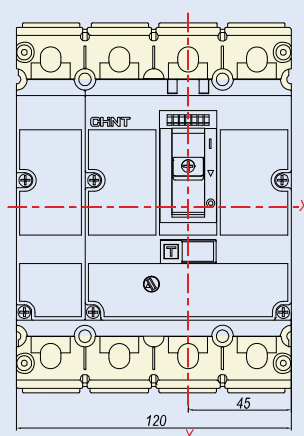

4P Short terminal cover

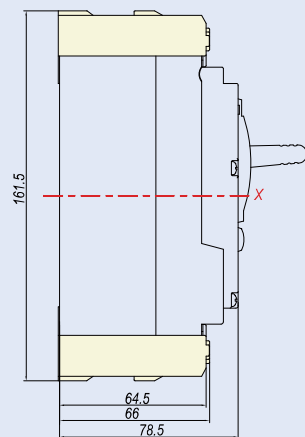

Unit:(mm)

8.2 NM8N-250

NM8N-250 Front connection (1P/2P)

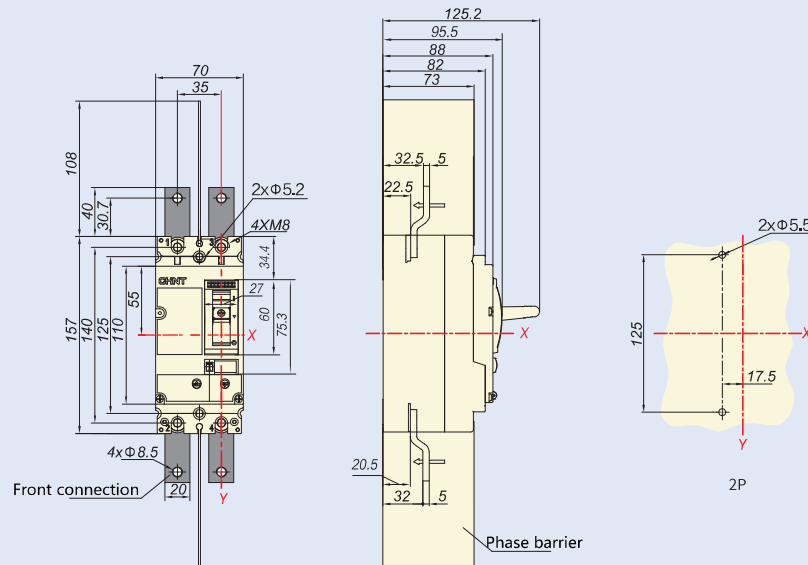
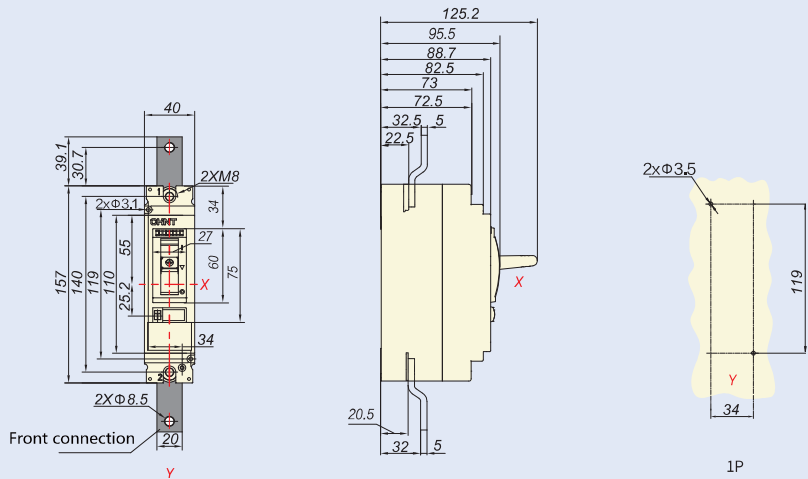

Unit:(mm)

NM8N-250 Front connection (3P/4P)

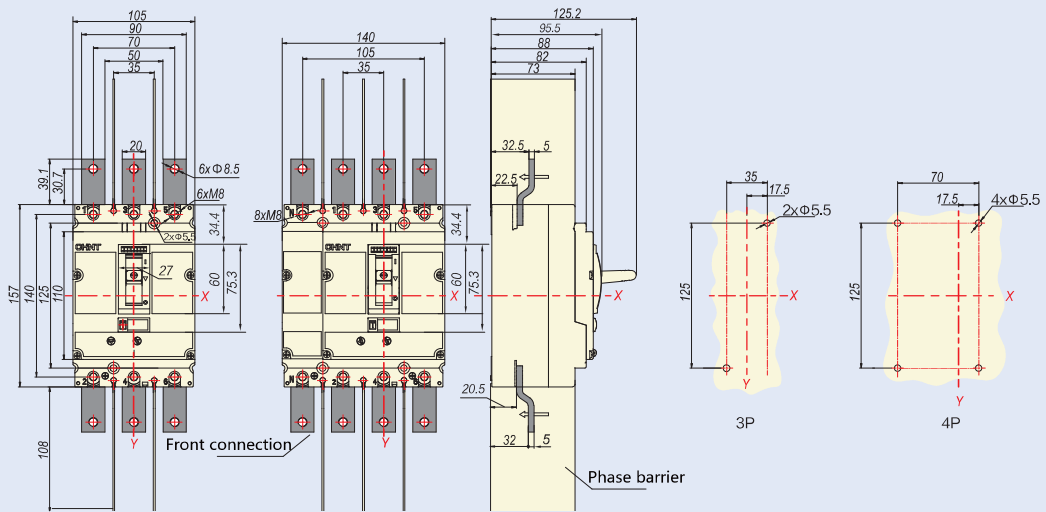

Unit:(mm)



NM8N-250 Rear connection (1P/2P)

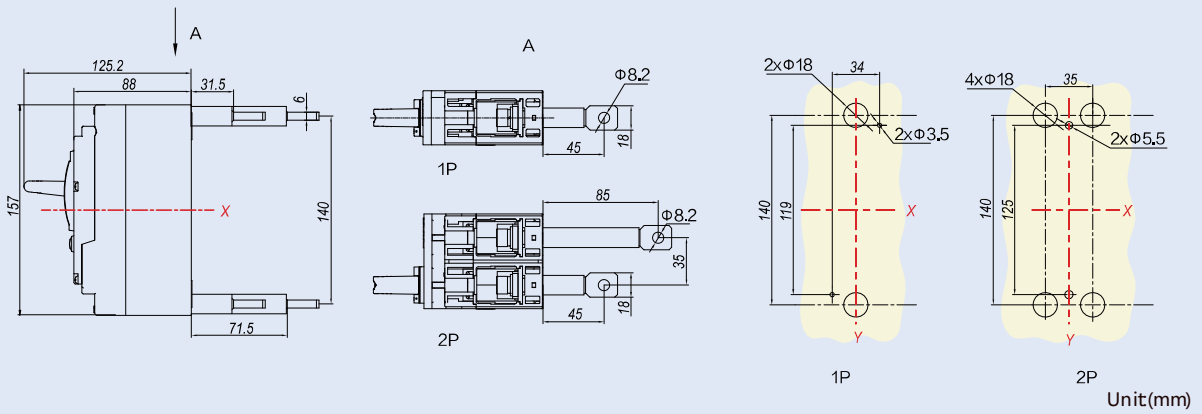

NM8N-250 Rear connection (3P/4P)

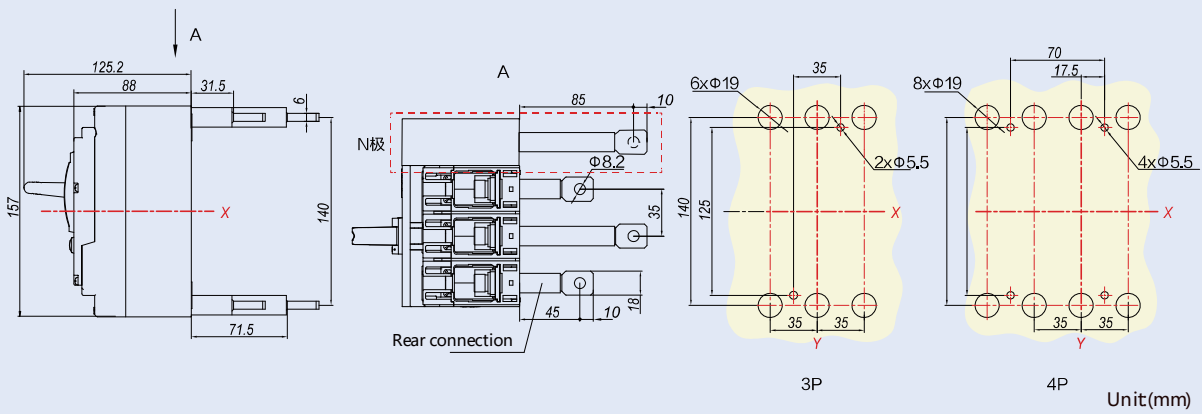

NM8N-250 Plug-in front connection

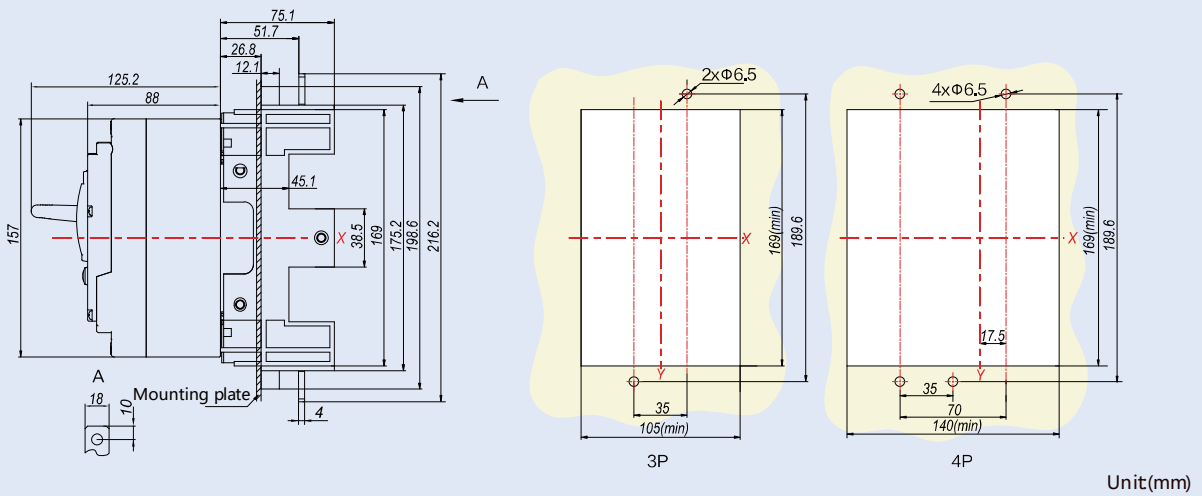

NM8N-250 Plug-in rear connection

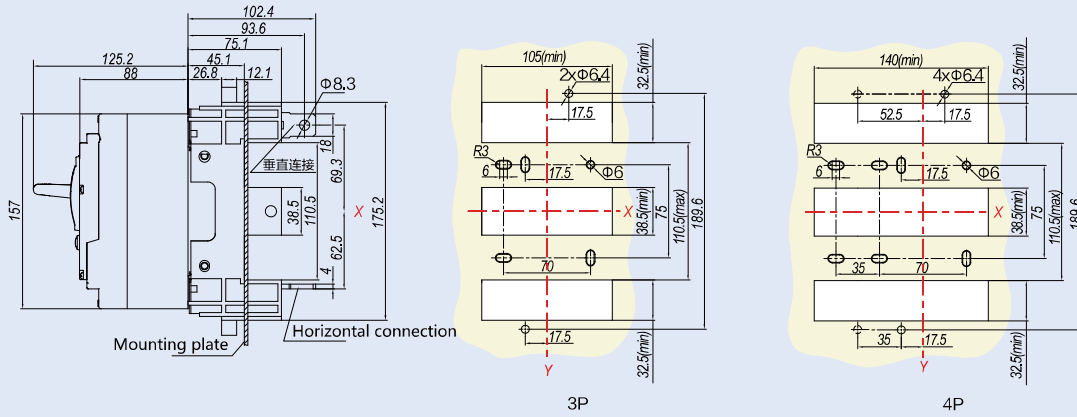

Unit:(mm)

NM8N-250 DIN-rail mounting

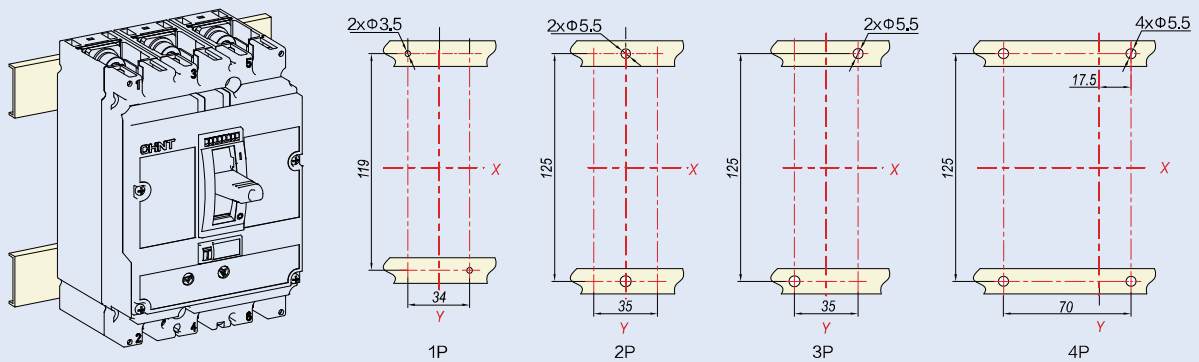

Unit:(mm)

NM8N-250 DIN-rail mounting (DIN-rail adapter is needed)

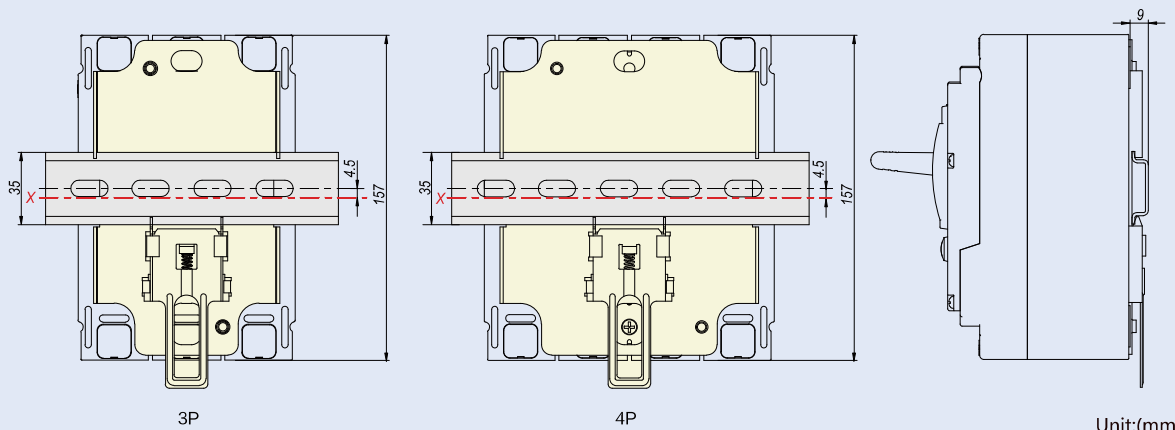

Unit:(mm)

B

NM8N-250 Mechanical interlock

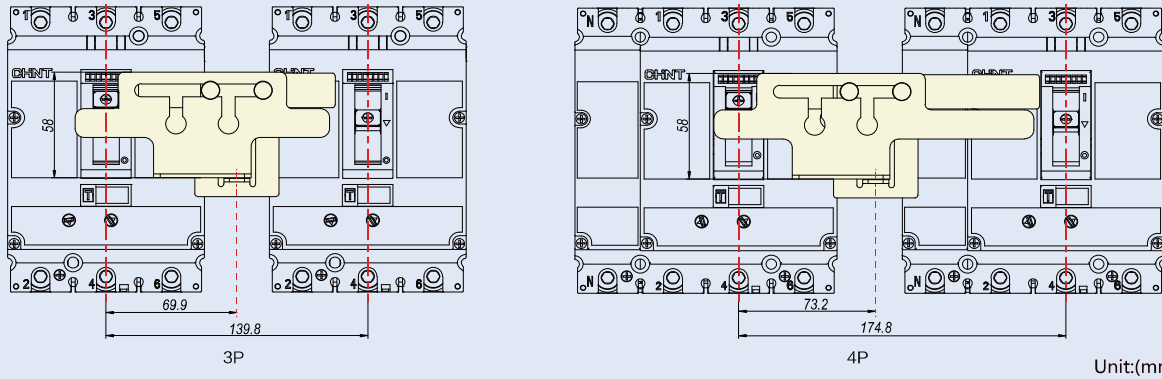

NM8N-250 Terminal cover

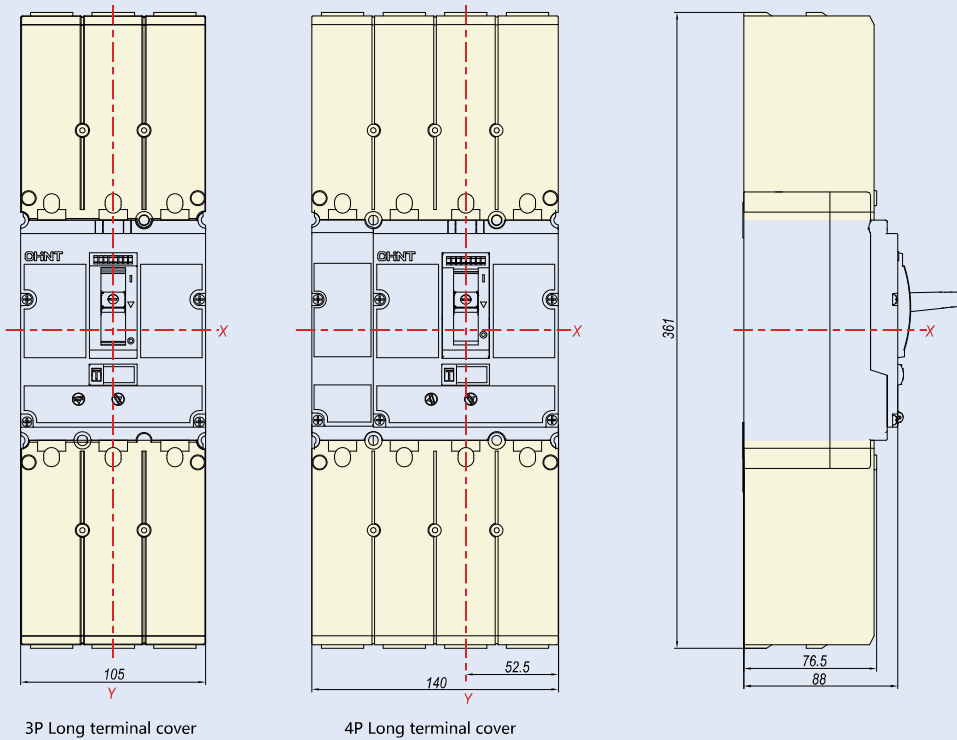
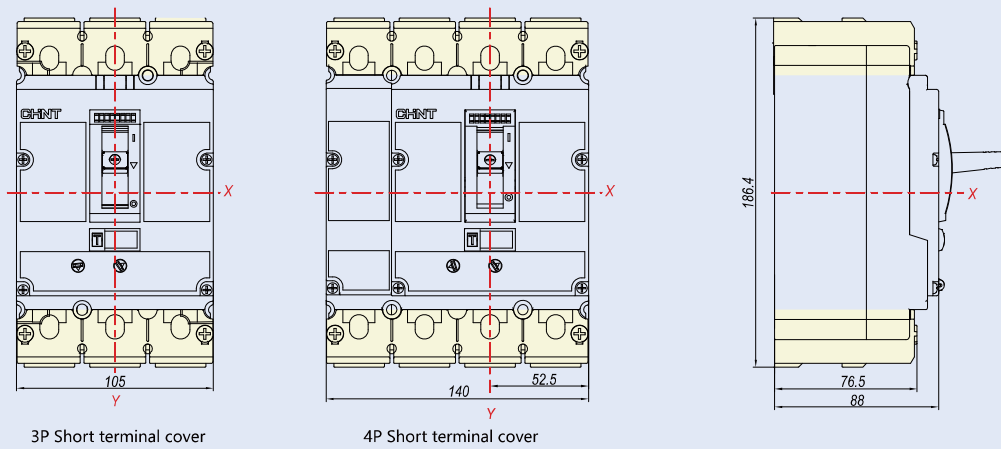

8.3 NM8N-400/630

NM8N-400/630 Front connection

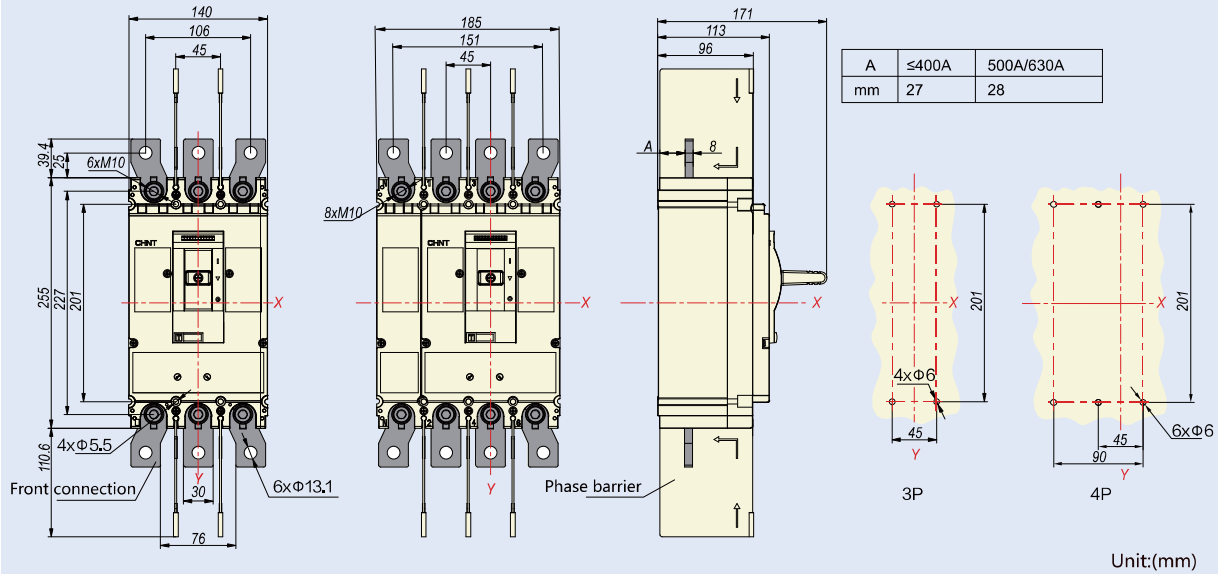

NM8N-400/630 Rear connection

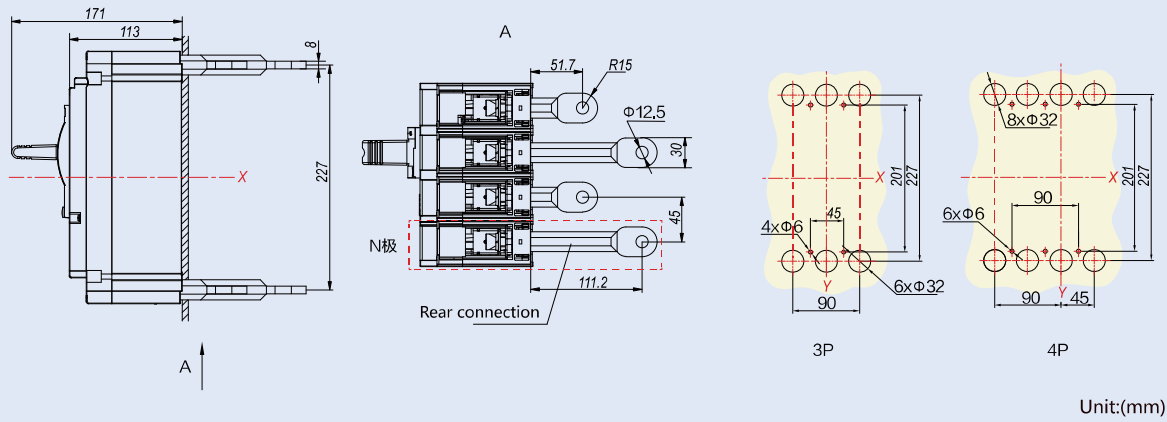

NM8N-400/630 Plug-in front connection

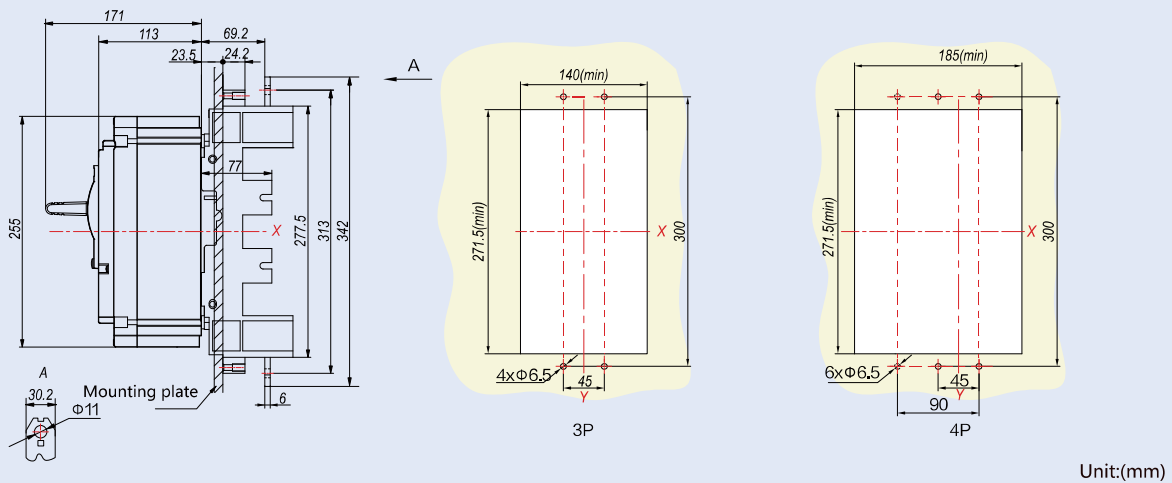

NM8N-400/630 Plug-in rear connection

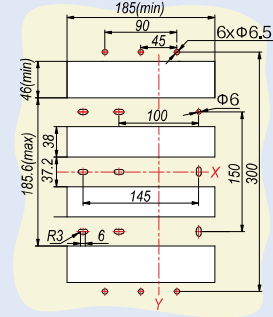
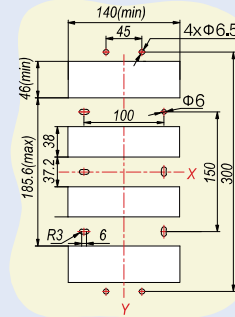
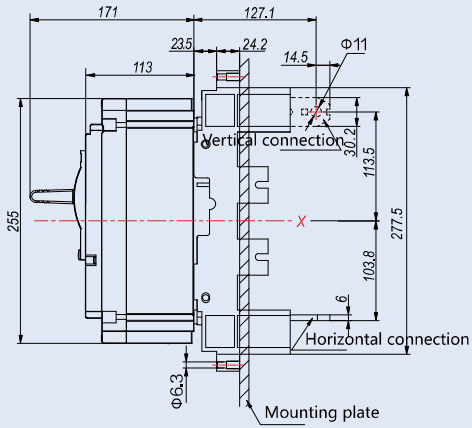

3P

4P

Unit:(mm)

NM8N-400/630 DIN-rail mounting

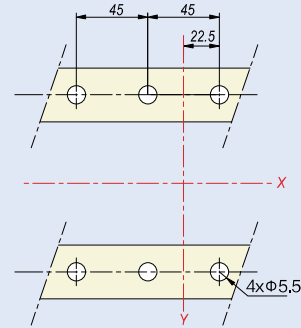
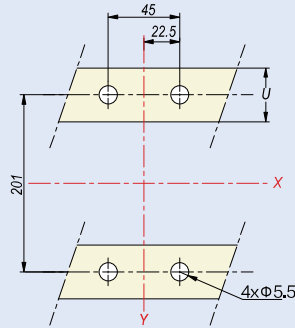
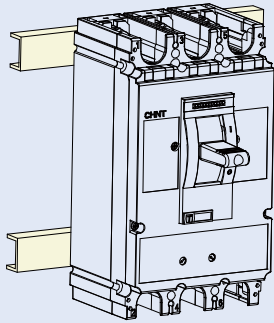

3P

4P

Unit:(mm)

NM8N-400/630 Mechanical interlock

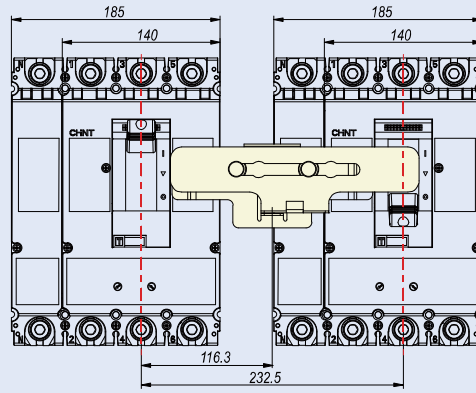
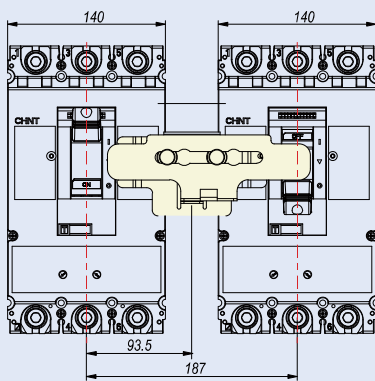

3P

4P

Unit:(mm)

NM8N-400/630 Long terminal cover

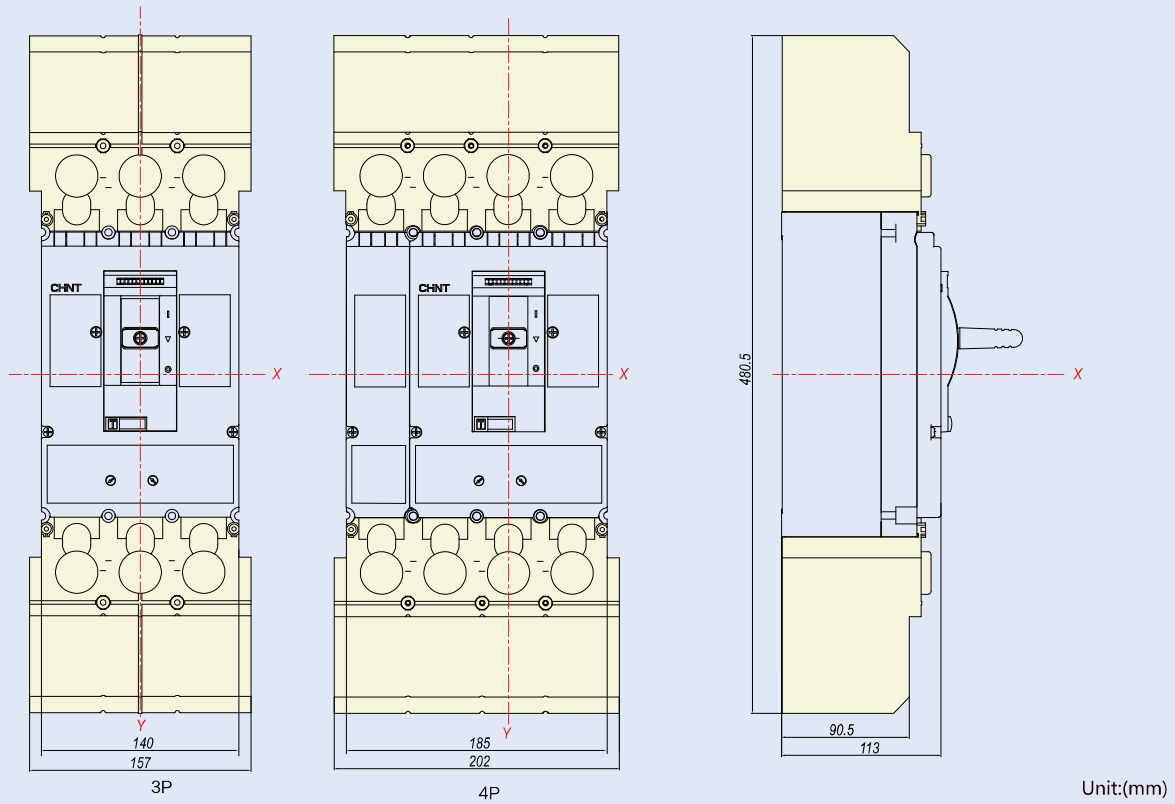

NM8N-400/630 Short terminal cover

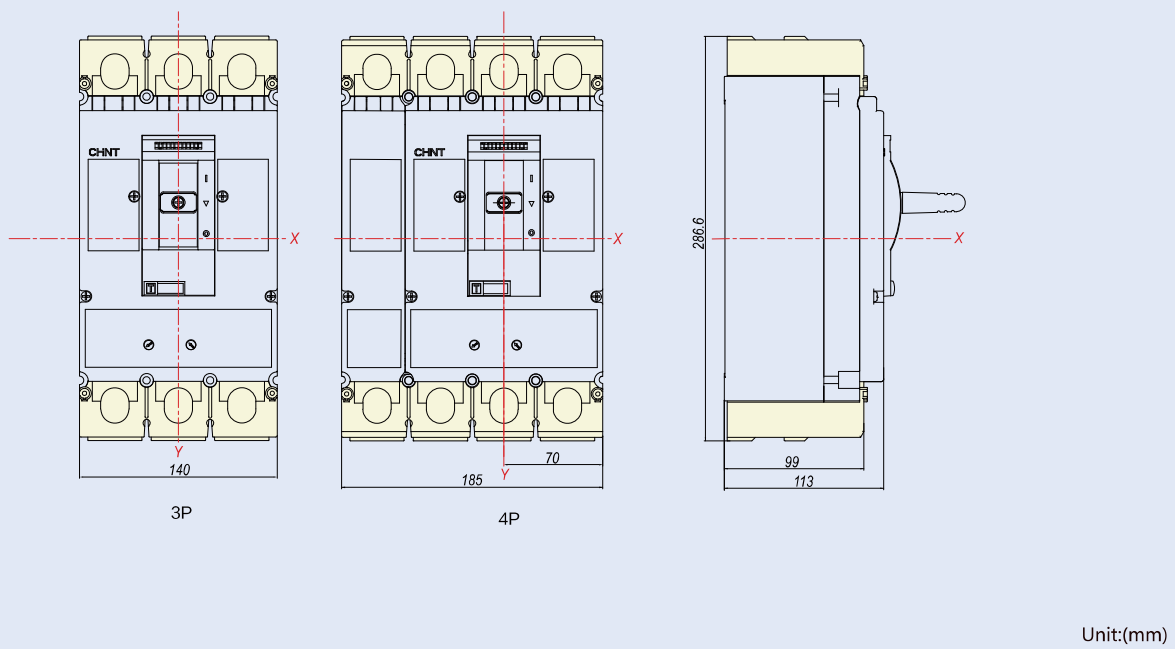



NM8N-400/630 Draw-out type

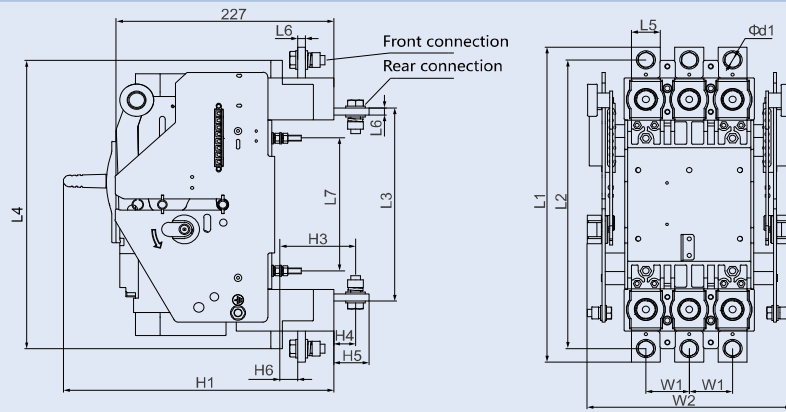

Unit:(mm)

Current	Pole	Dimension														
		L1	L2	L3	L4	L5	L6	L7	H1	H3	H4	H5	H6	W1	W2	Φd1
In≤400A	3P	342	313	207	312	30	6	143	280	77	21	35.5	17.5	45	214	11
	4P	342	313	207	312	30	6	143	280	77	21	35.5	17.5	45	259	11
In>400A	3P	342.5	314.5	210.5	313.5	30	8	143	280	77.5	21.5	35.5	17.5	45	214	11
	4P	342.5	314.5	210.5	313.5	30	8	143	280	77.5	21.5	35.5	17.5	45	259	11

DIN-rail mounting

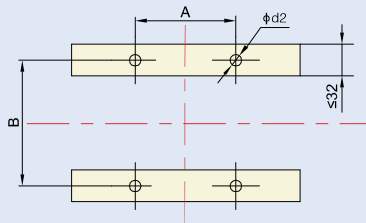
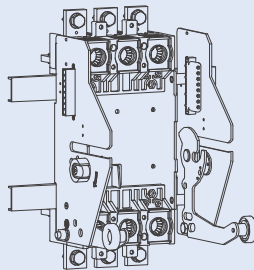

Pole	Installation dimension		
	A	B	Φd2
3P	90	143	6.5
4P	135	143	6.5

DIN-rail mounting

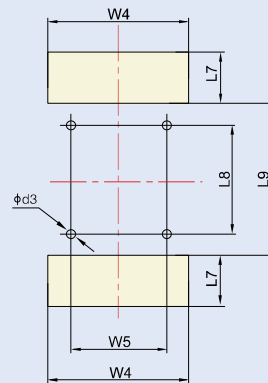
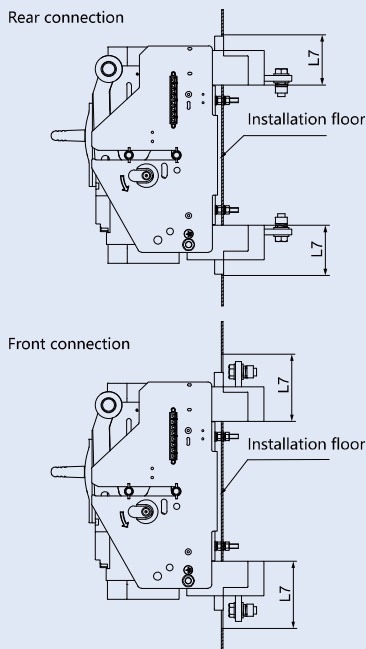

Current	Installation dimension of rear plate connection						
	L8	W5	L9	L7	W4	Φd3	Pole
In≤400A	143	90	181	70	138	7	3P
	143	135	181	70	182	7	4P
In>400A	144.5	90	182.5	70	138	7	3P
	144.5	135	182.5	70	182	7	4P

L7=90 when it is front connection, the rest of dimensions are the same with rear connection

8.4 NM8N-800

NM8N-800 Front connection (3P)

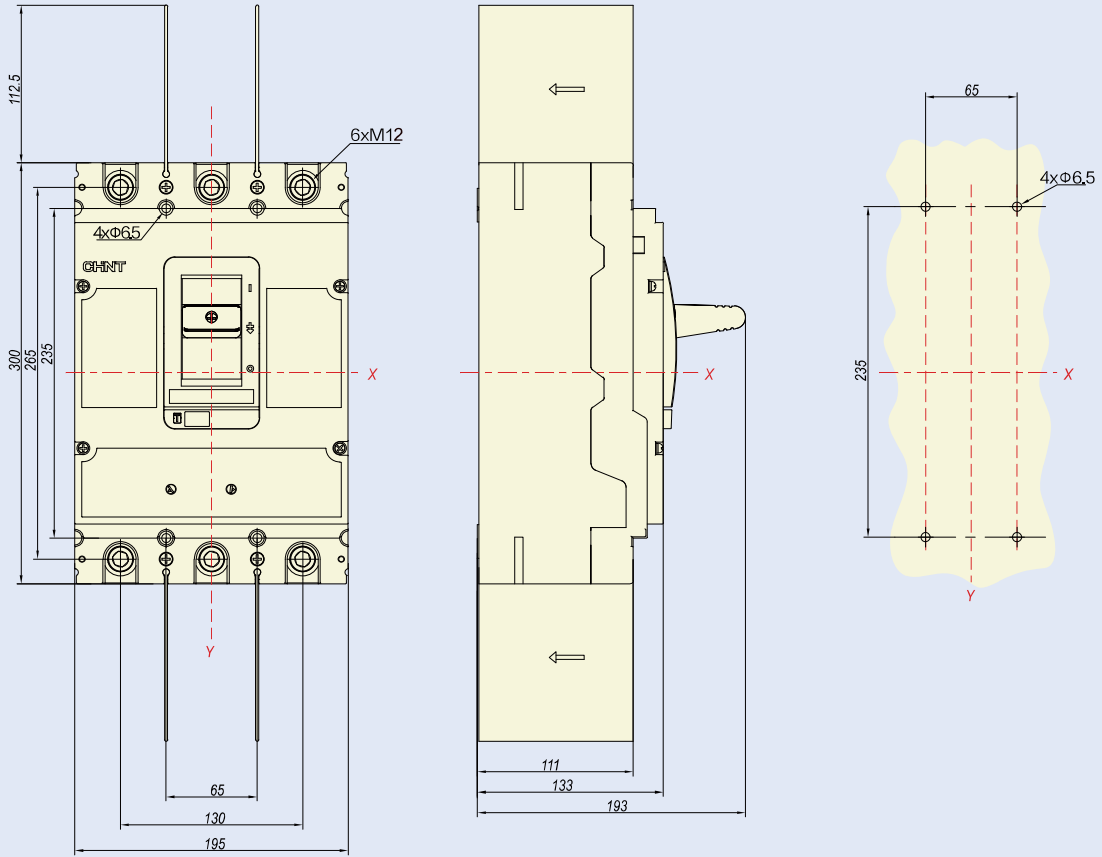

Unit:(mm)

B

NM8N-800 Front connection (4P)

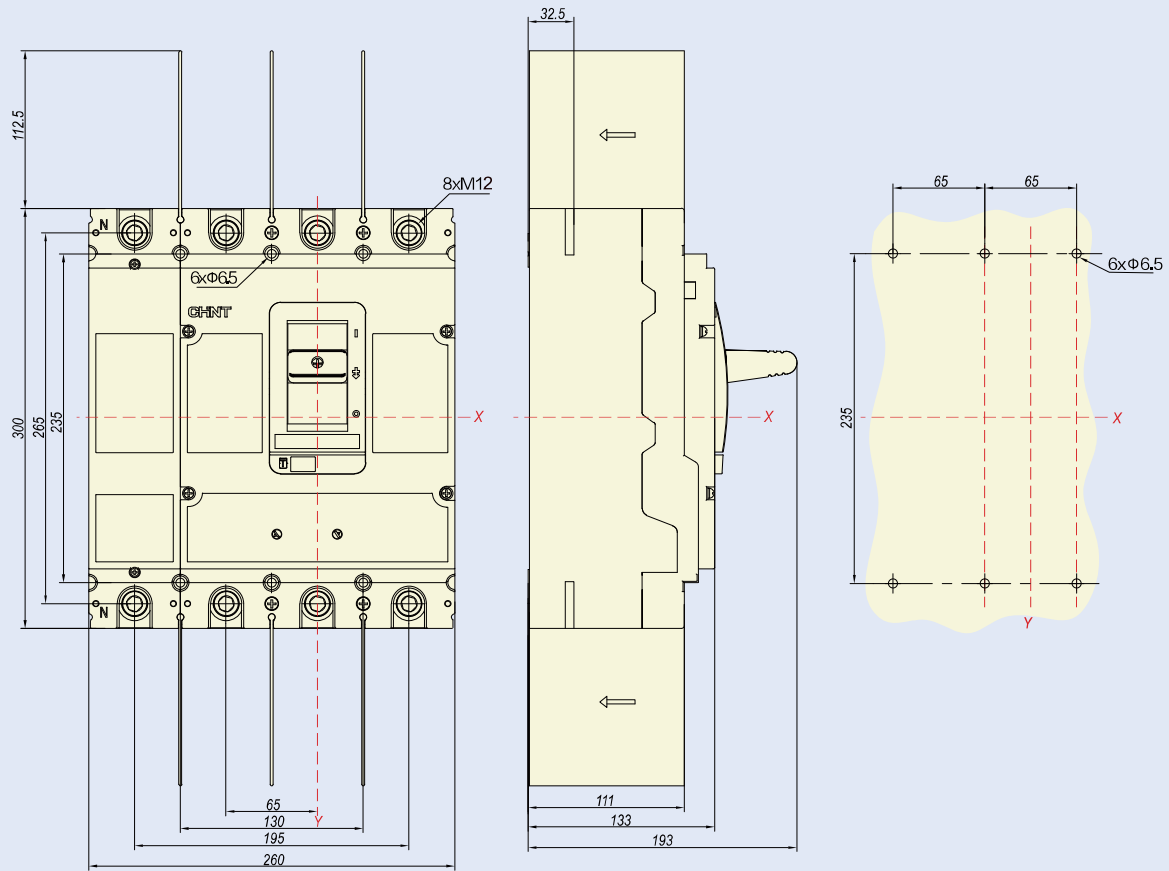

Unit:(mm)

NM8N-800 Rear connection

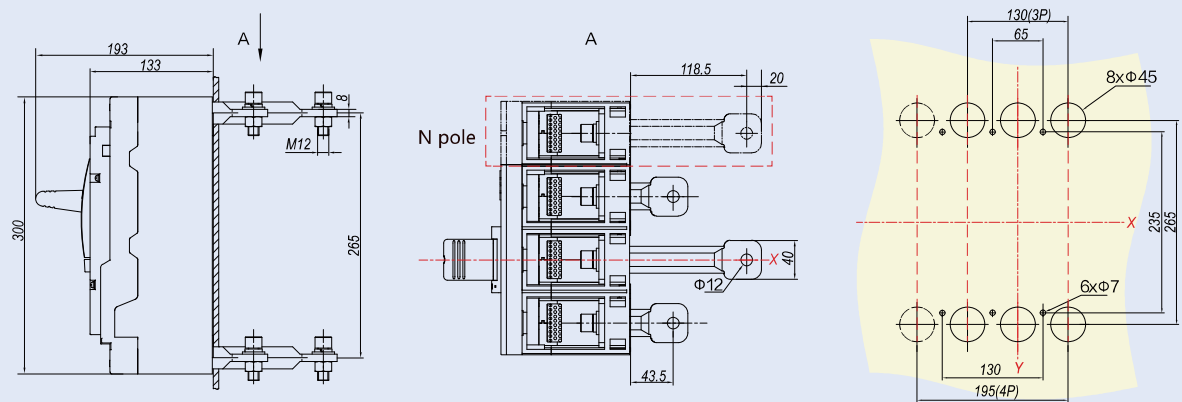

3P/4P Unit:(mm)

NM8N-800 Mechanical interlock

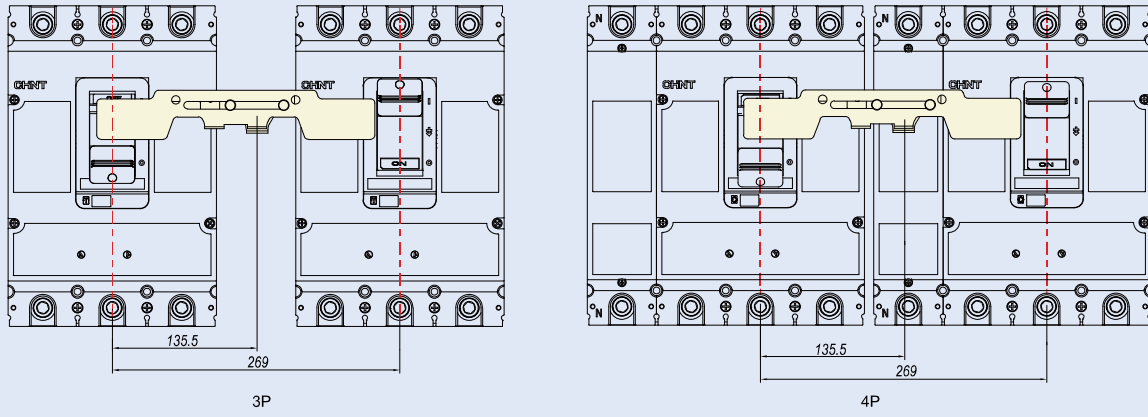

Unit:(mm)

NM8N-800 Short terminal cover

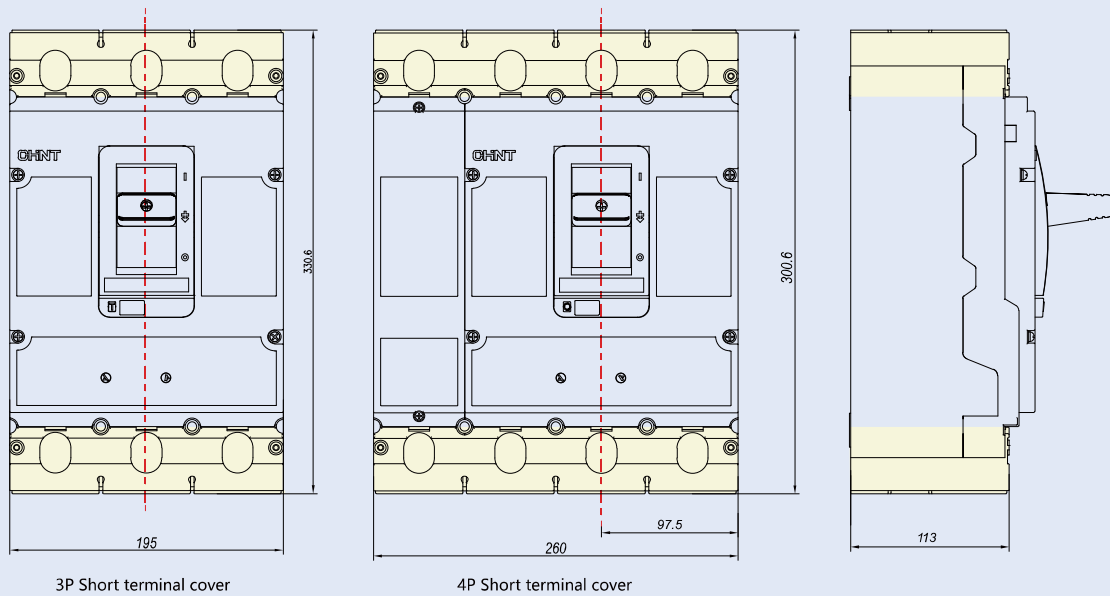

Unit:(mm)

NM8N-800 Long terminal cover

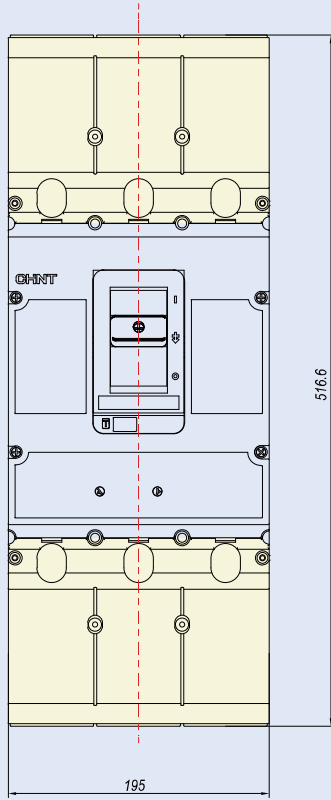

3P Long terminal cover

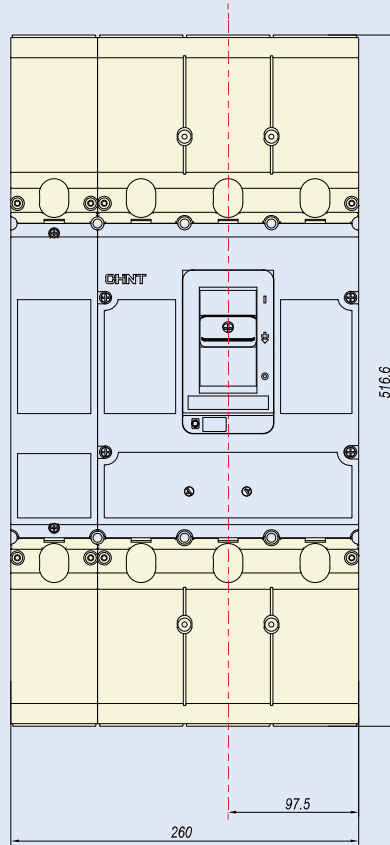

4P Long terminal cover

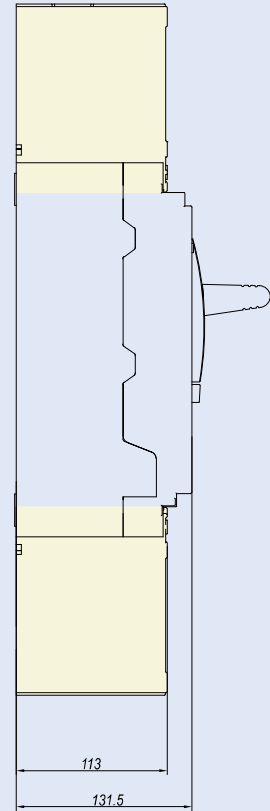

Unit:(mm)

B

NM8N-800 Draw-out type

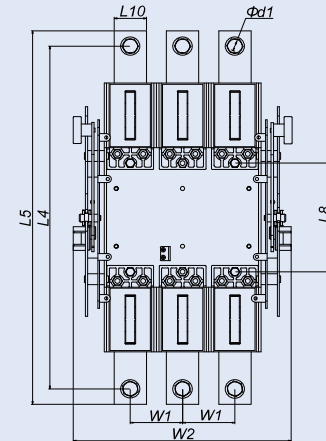
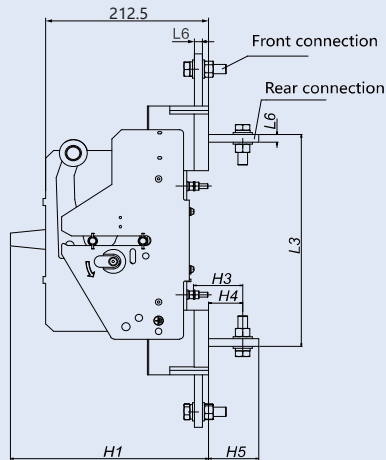

Unit:(mm)

Pole	Dimension													
	L3	L4	L5	L6	L8	L10	H1	H3	H4	H5	W1	W2	Φd1	
3P	275	445	485	10	141	40	270	61	42.5	62.5	65	281	13	
4P	275	445	485	10	141	40	270	61	42.5	62.5	65	346	13	

DIN-rail mounting

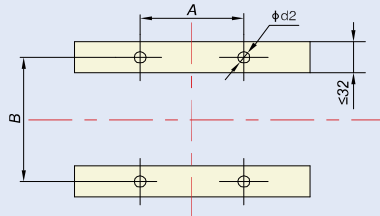
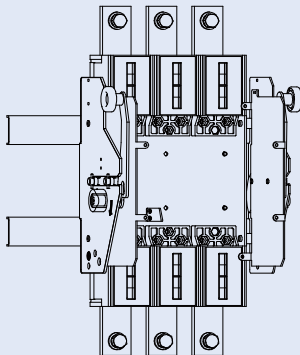

Pole	Installation dimension		
	A	B	Φd2
3P	130	141	7
4P	195	141	7

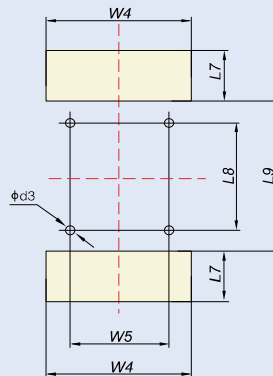
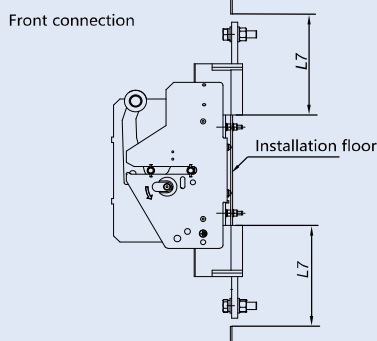
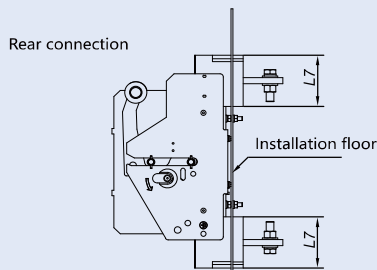

Pole	Installation dimension					
	L8	W5	L9	L7	W4	Φd3
3P	141	130	177	95	200	7
4P	141	195	177	95	265	7

L7=200 when it is front connection, the rest of dimensions are the same with rear connection

8.5 NM8N-1600

NM8N-1600 Front connection (Manual type 3P)

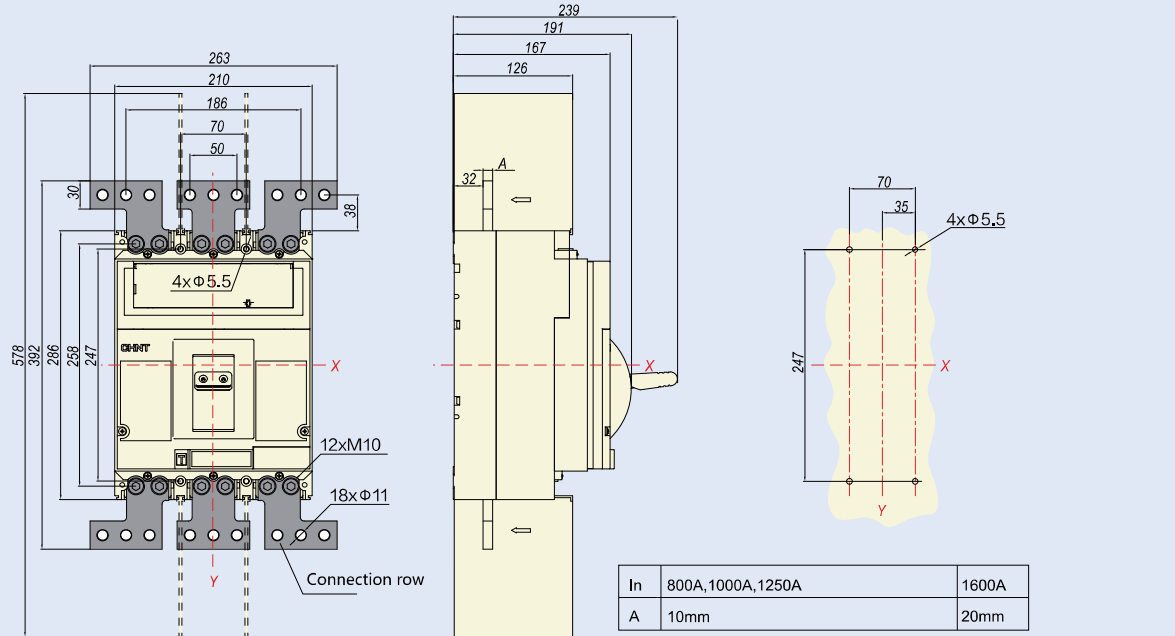

Unit:(mm)

NM8N-1600 Front connection (Manual type 4P)

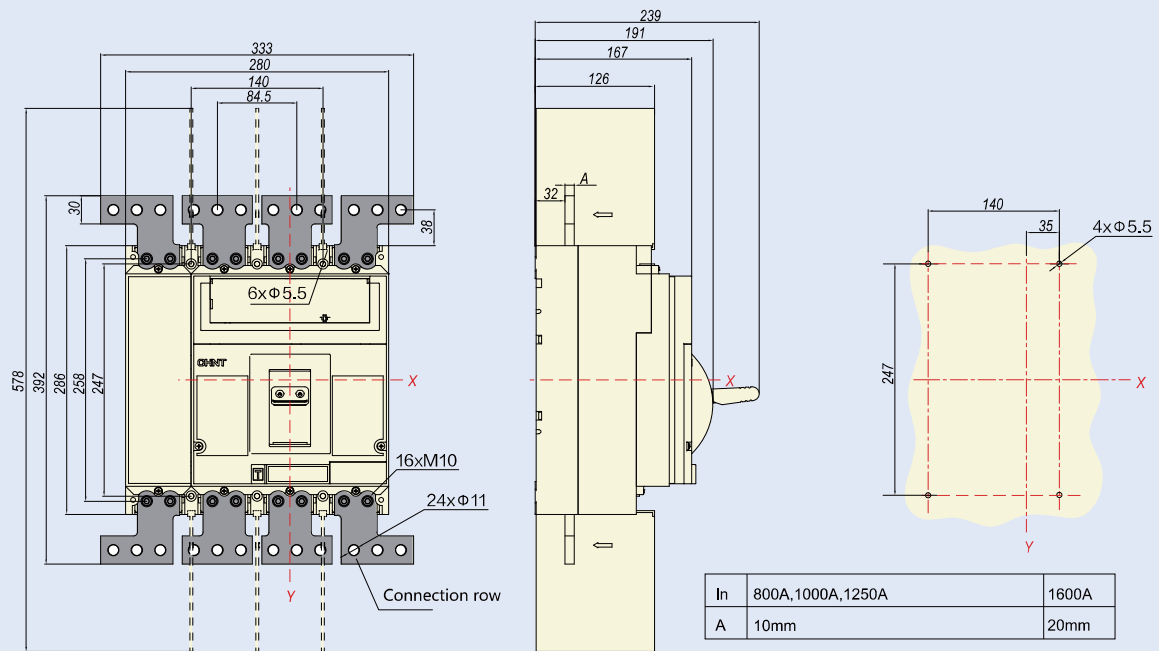

Unit:(mm)

NM8N-1600 Front connection (Motor type 3P)

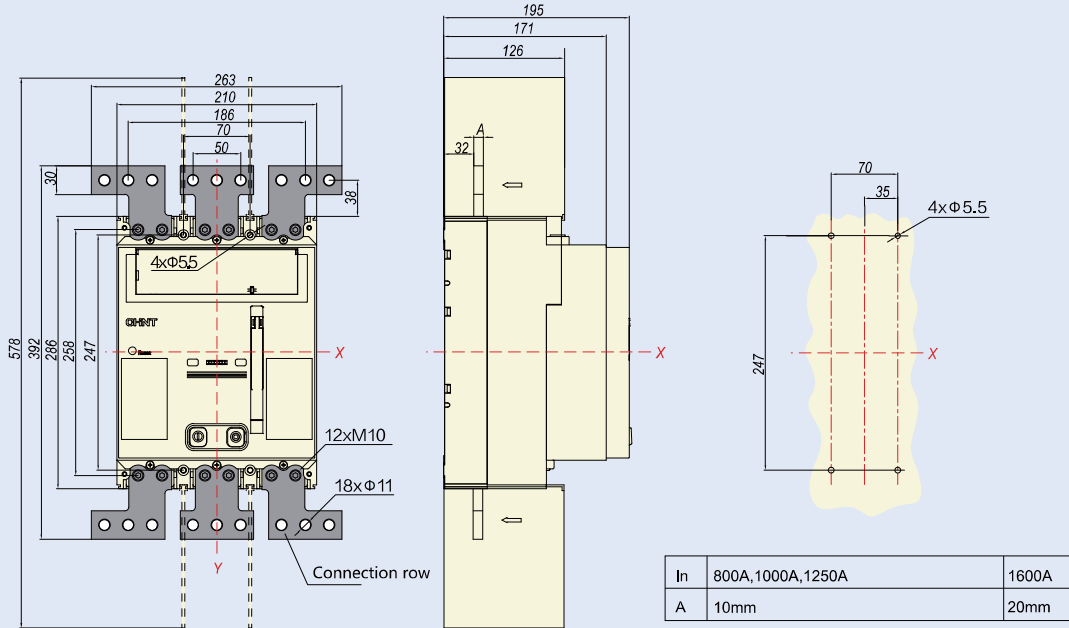

Unit:(mm)

NM8N-1600 Front connection (Motor type 4P)

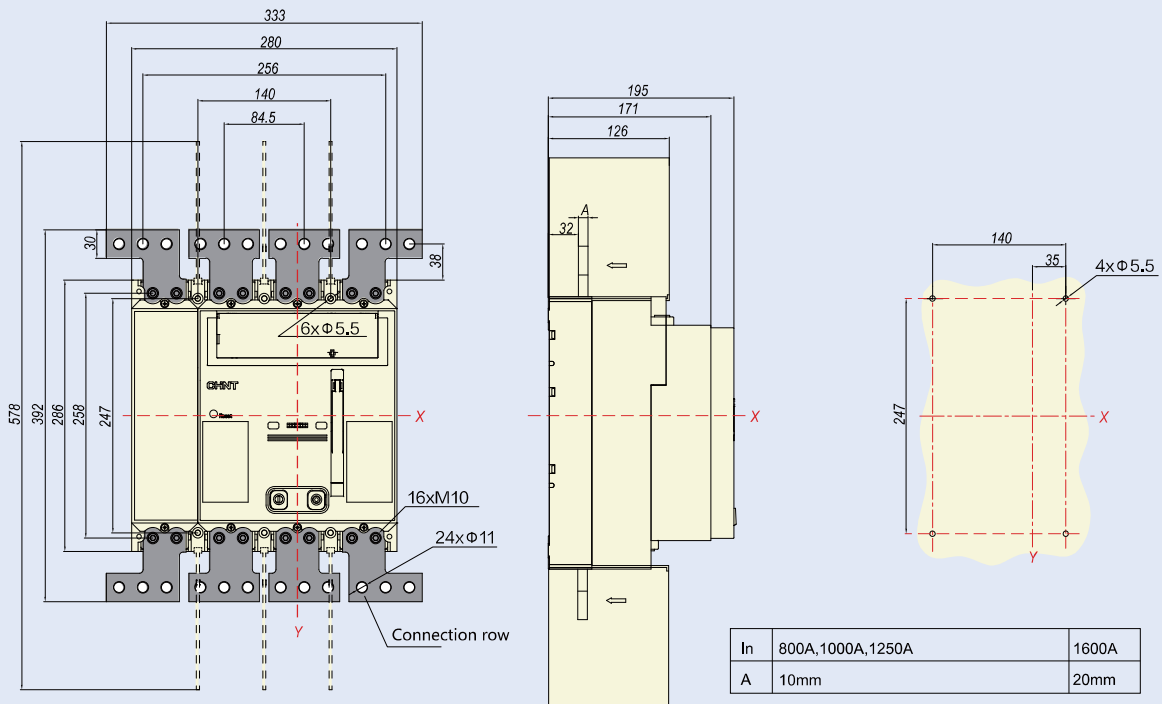

Unit:(mm)

8.6 NM8NL

NM8NL-125 Front connection

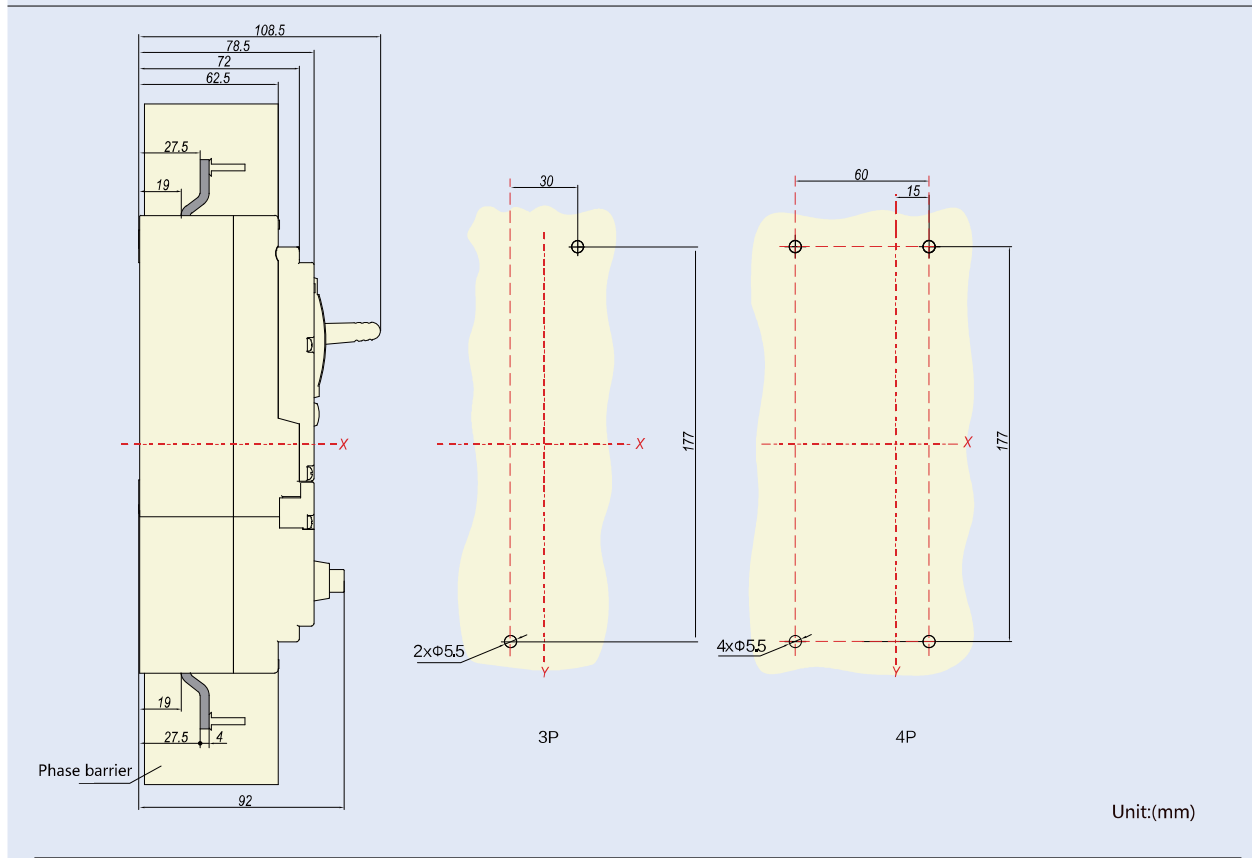
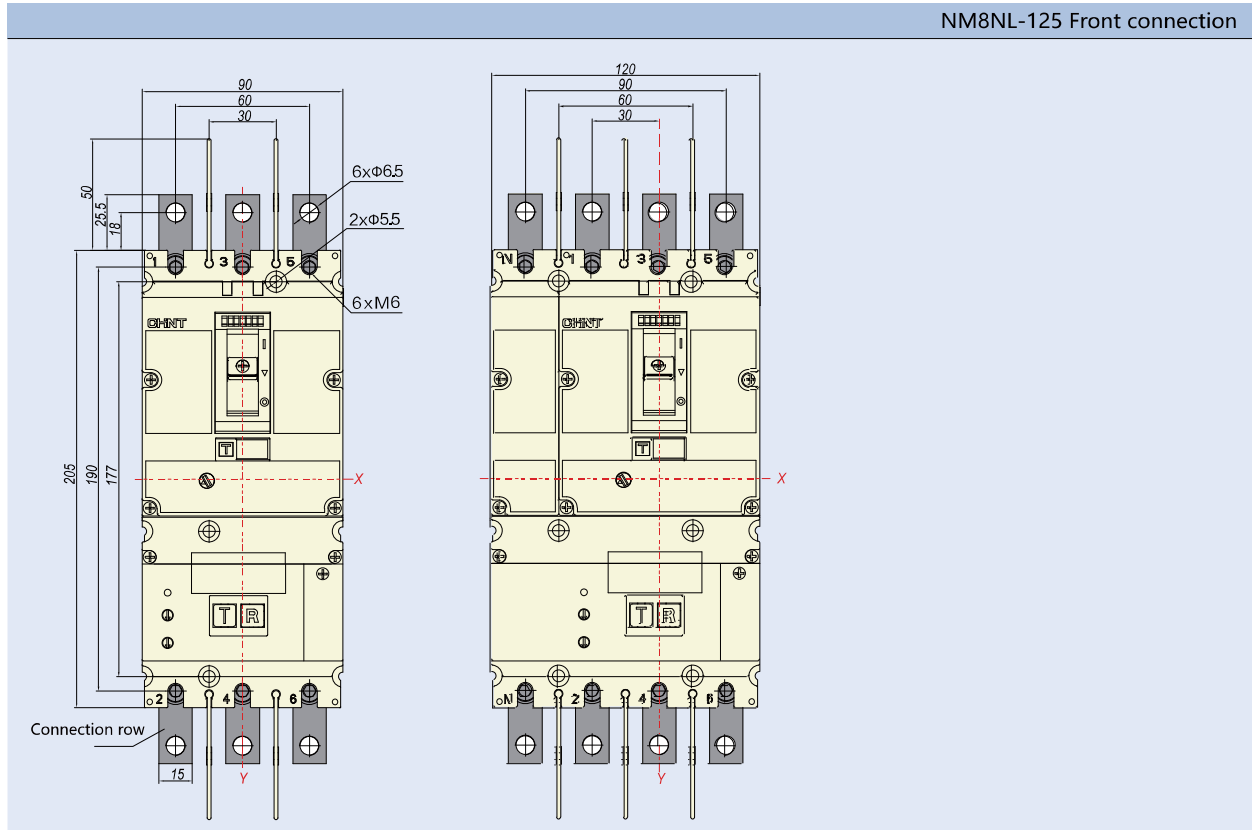

Unit:(mm)



NM8NL-125 Rear connection

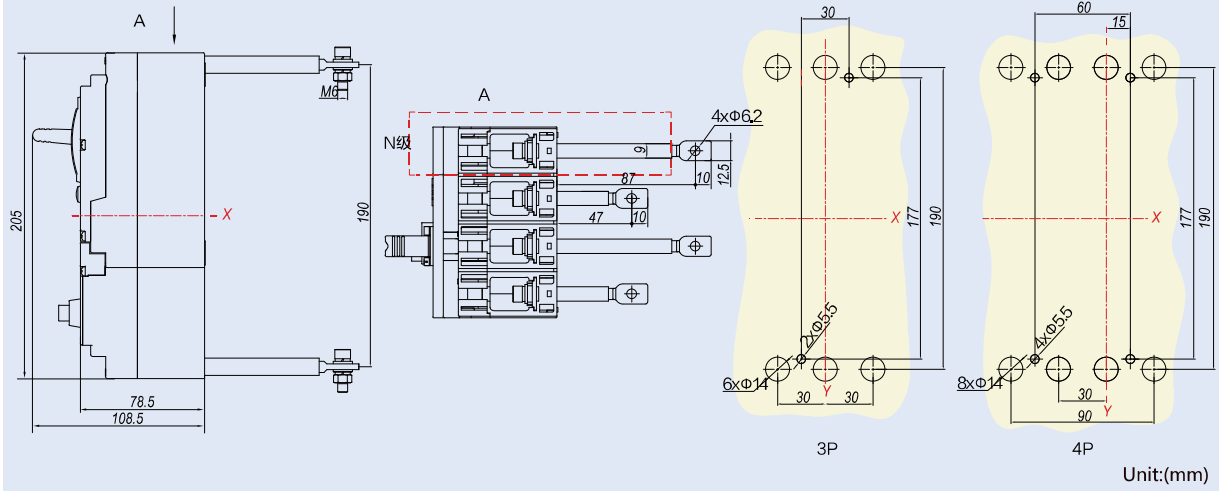

NM8NL-125 DIN-rail mounting

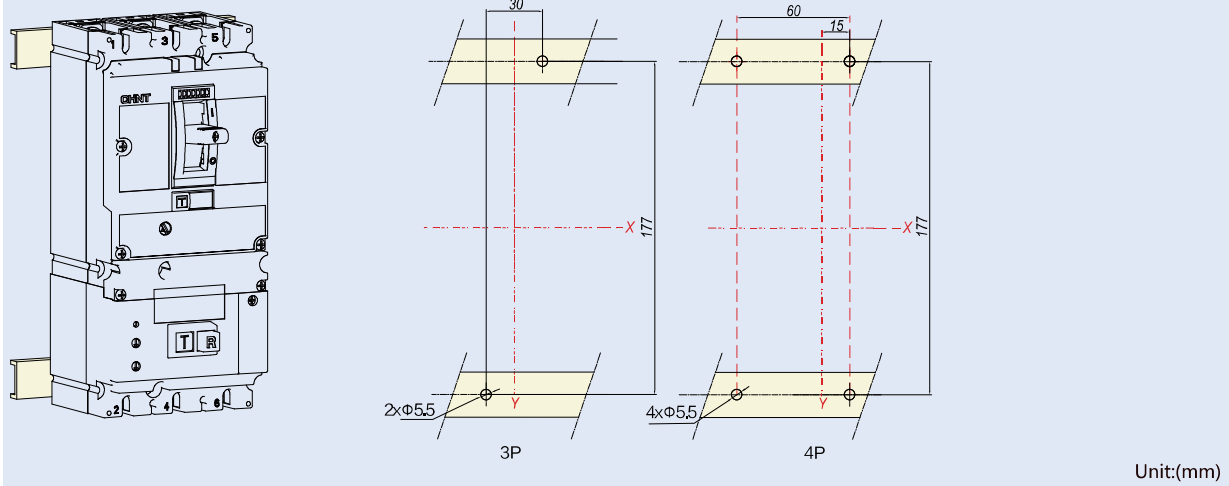

B

NM8NL-250 Front connection

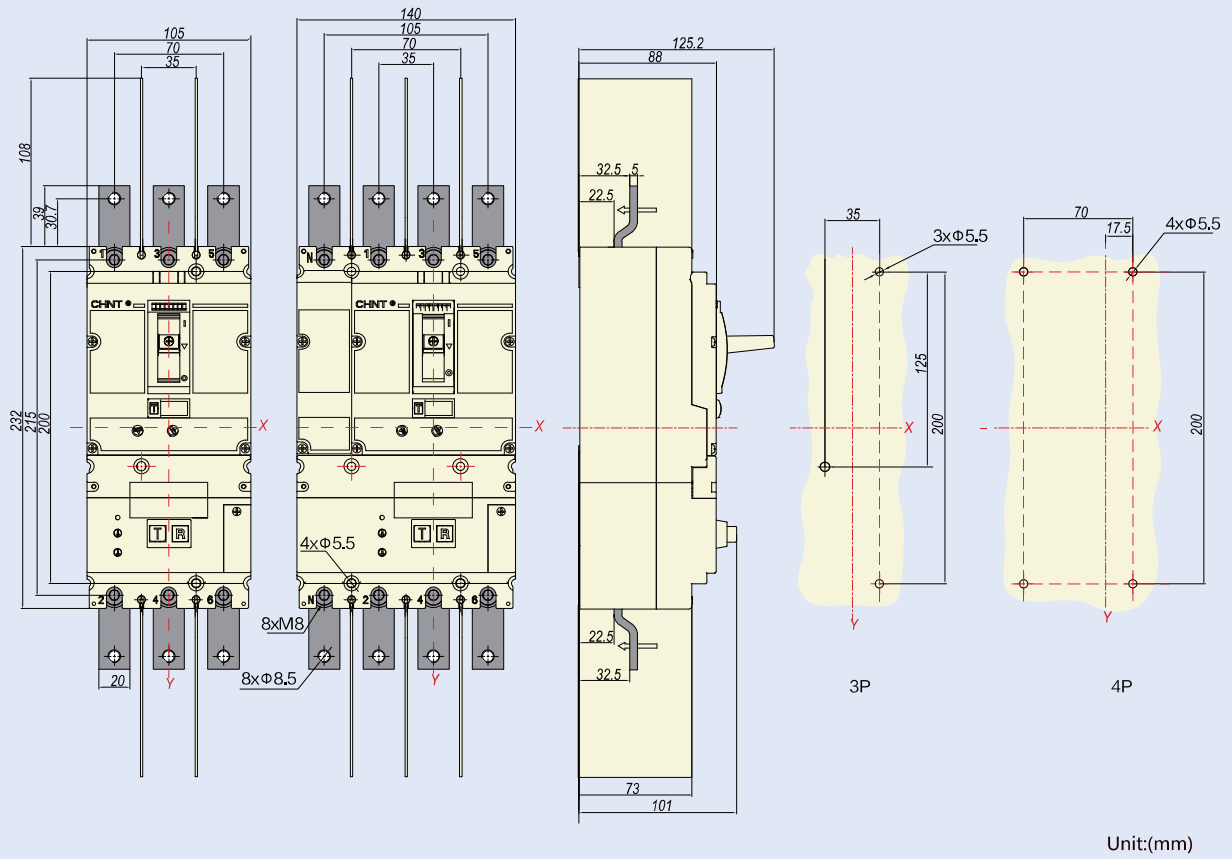

NM8NL-250 Rear connection

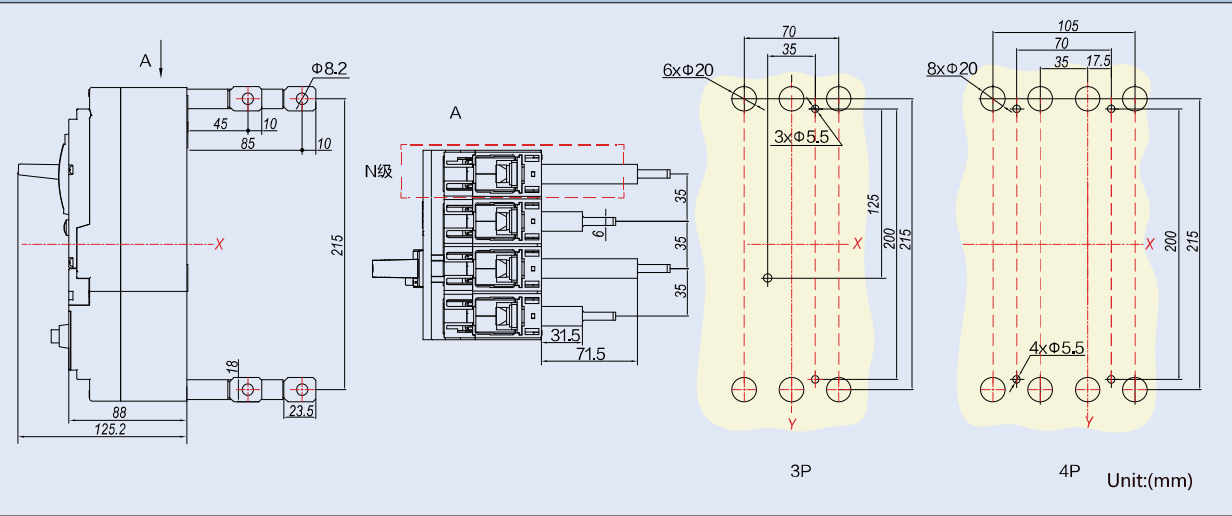

NM8NL-250 DIN-rail mounting

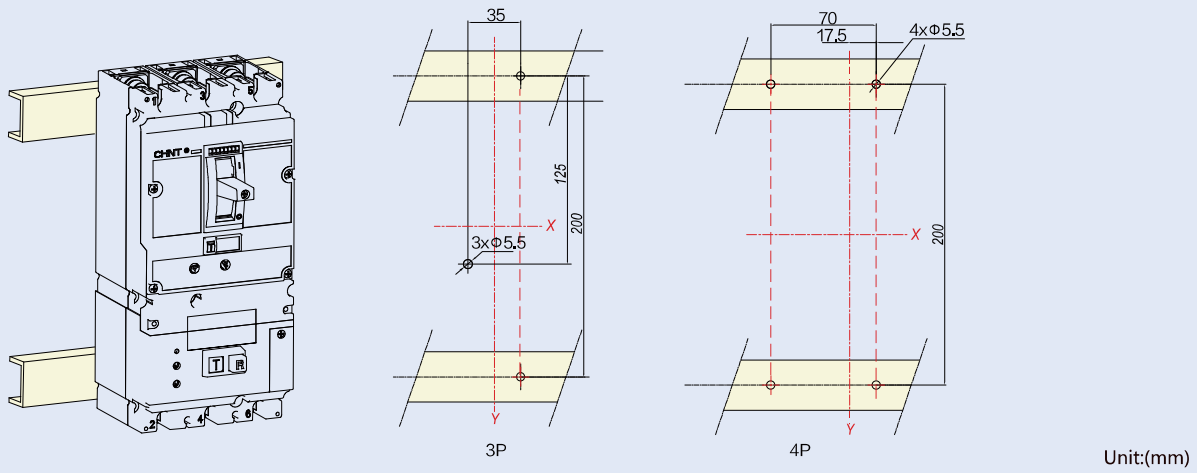

NM8NL-400/630 Front connection

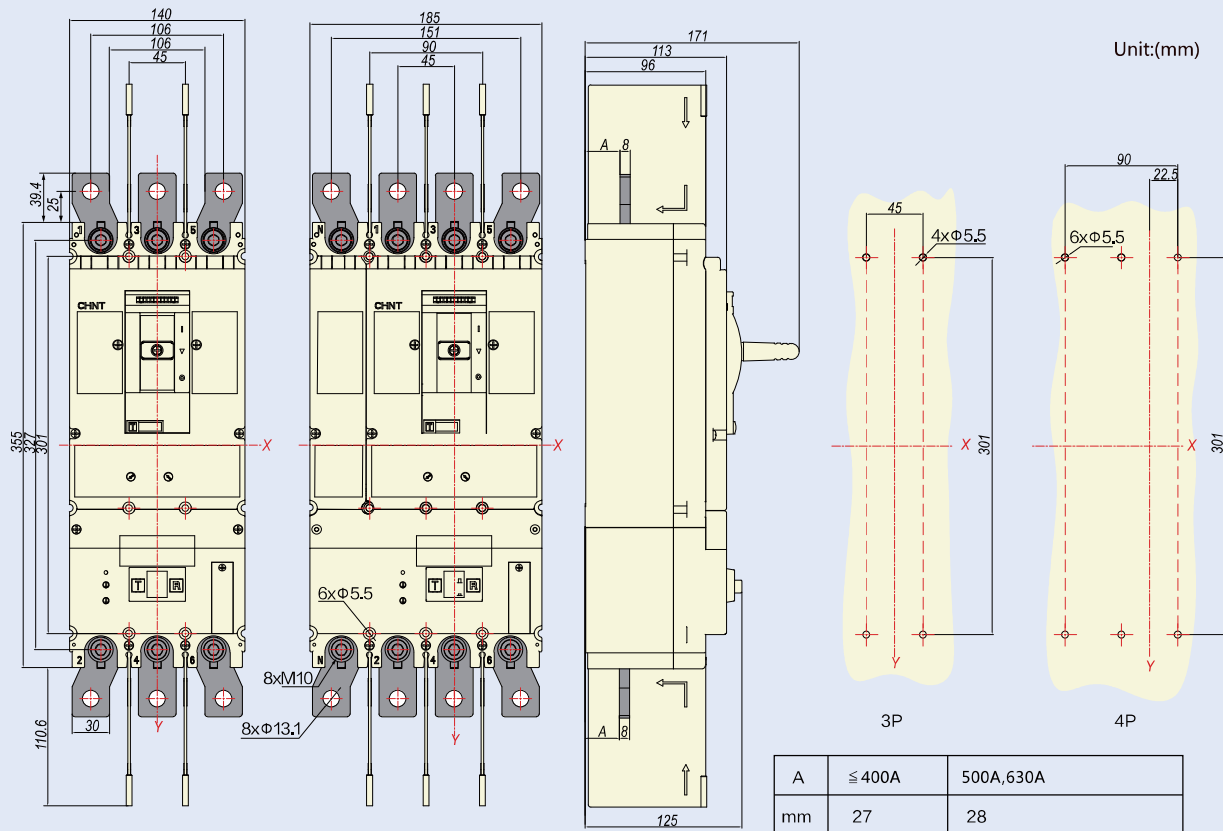

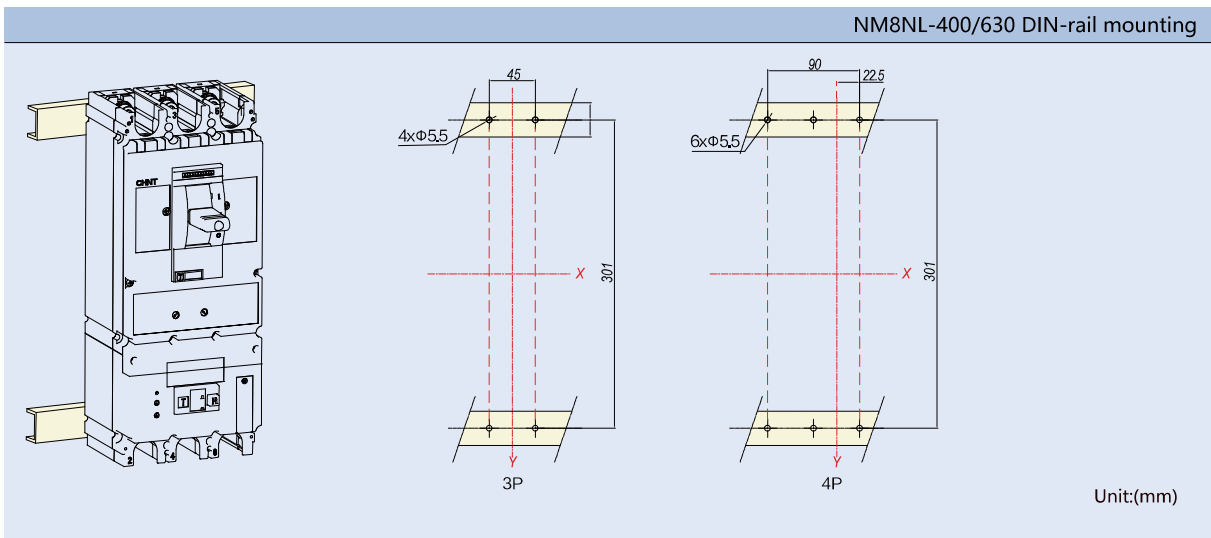
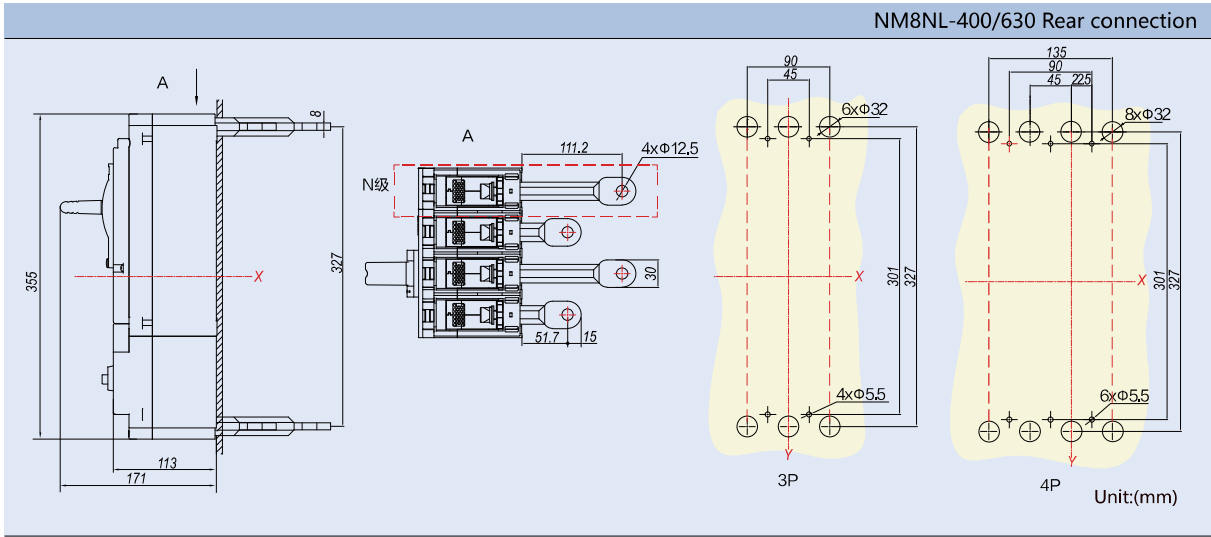

8.7 NM8N Wiring diagram

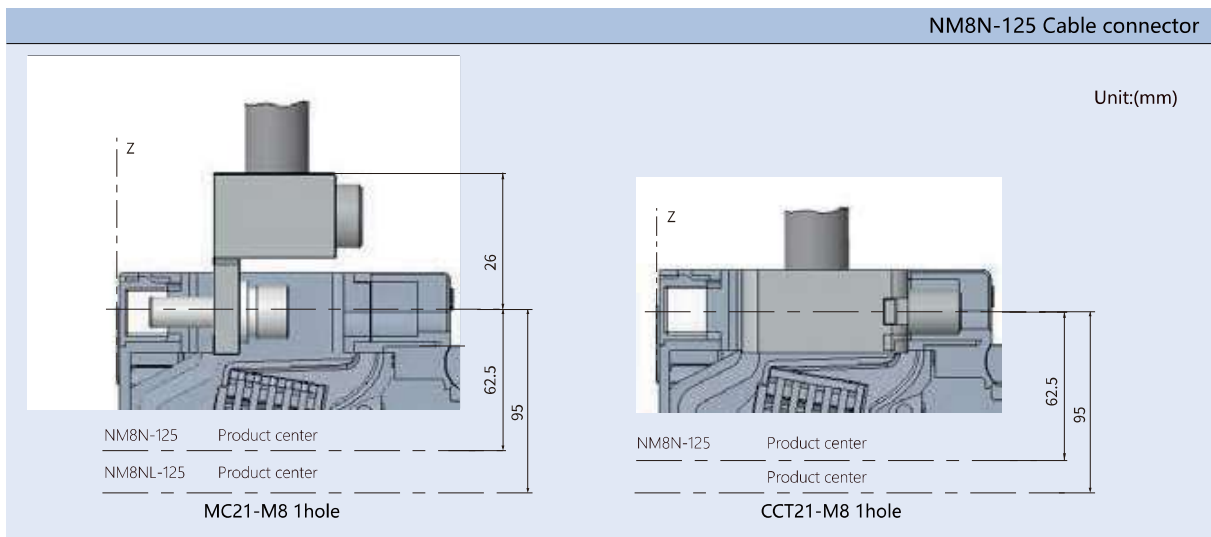

NM8N-250 Cable connector

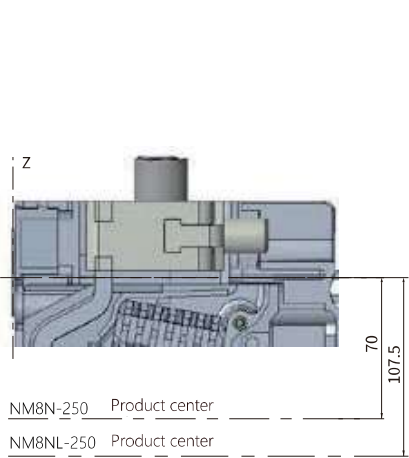

CCT22-M8 1 hole

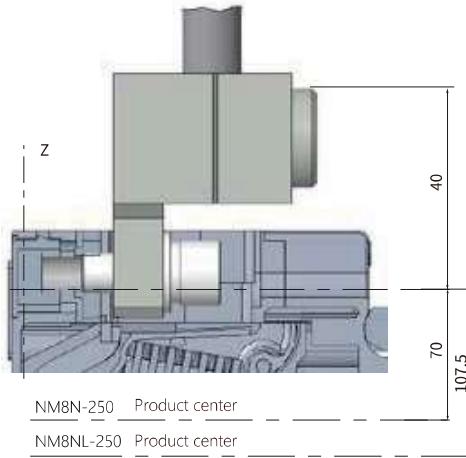

MC22-M8 1 hole

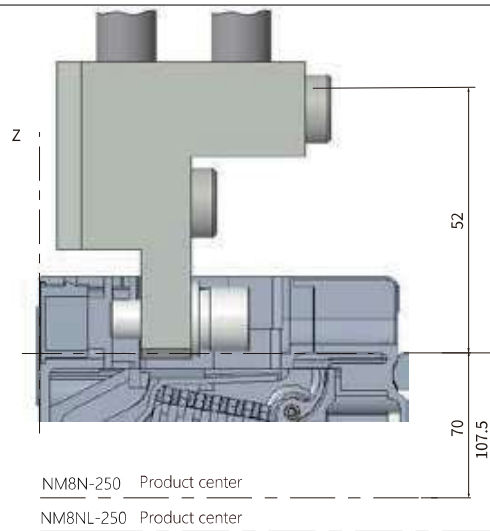

MC22-M8 2 hole

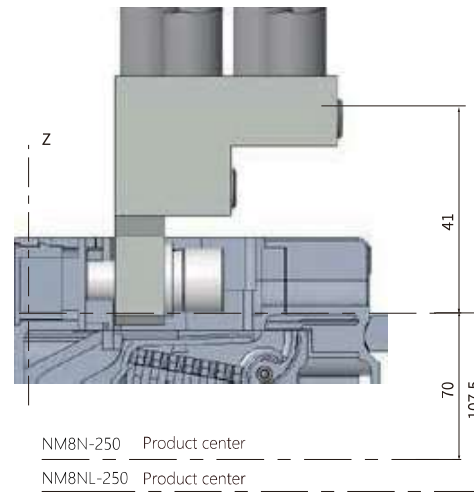

MC22-M8 6 hole

Unit:(mm)

NM8N-630 Cable connector

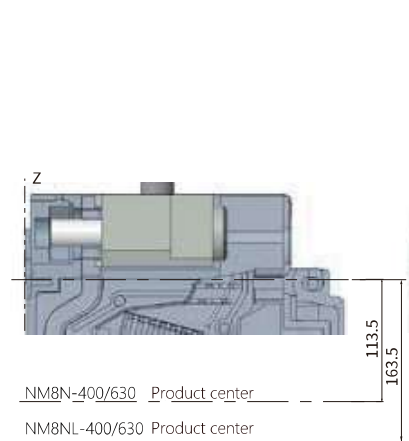

CCT23-M8 1 hole

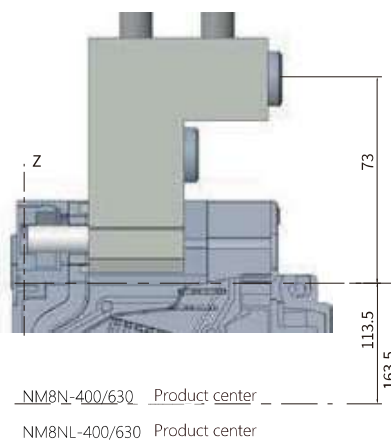

MC23-M8 2 hole

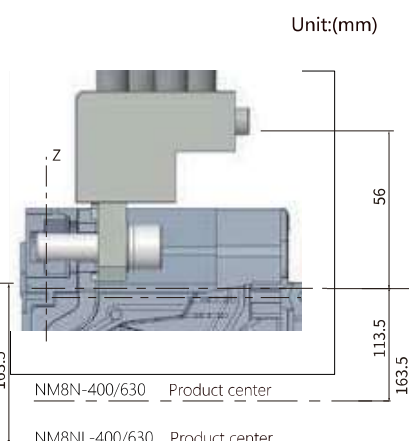

MC23-M8 4 hole

Unit:(mm)

B

NM8N-800 Cable connector

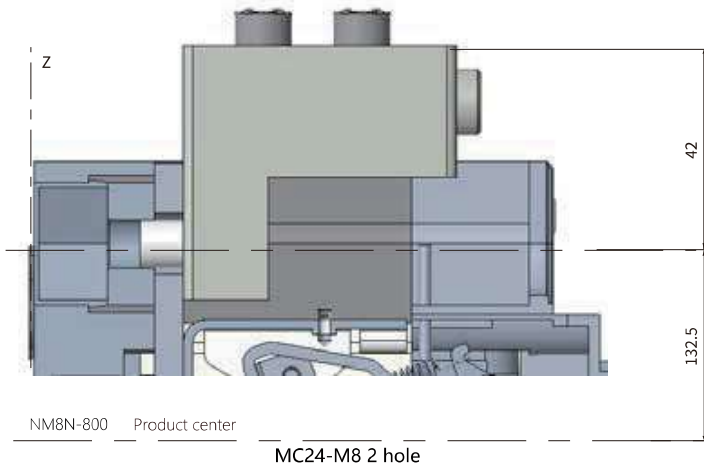

Unit:(mm)

NM8N-1600 Cable connector

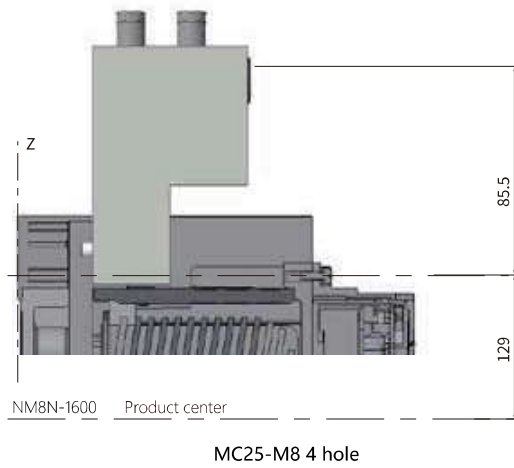

Unit:(mm)

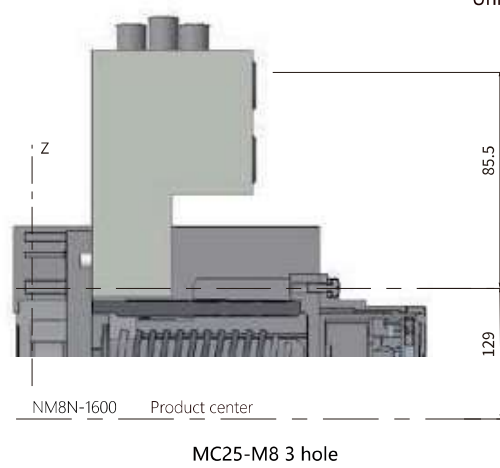

MC25-M8 3 hole

8.8 Wiring

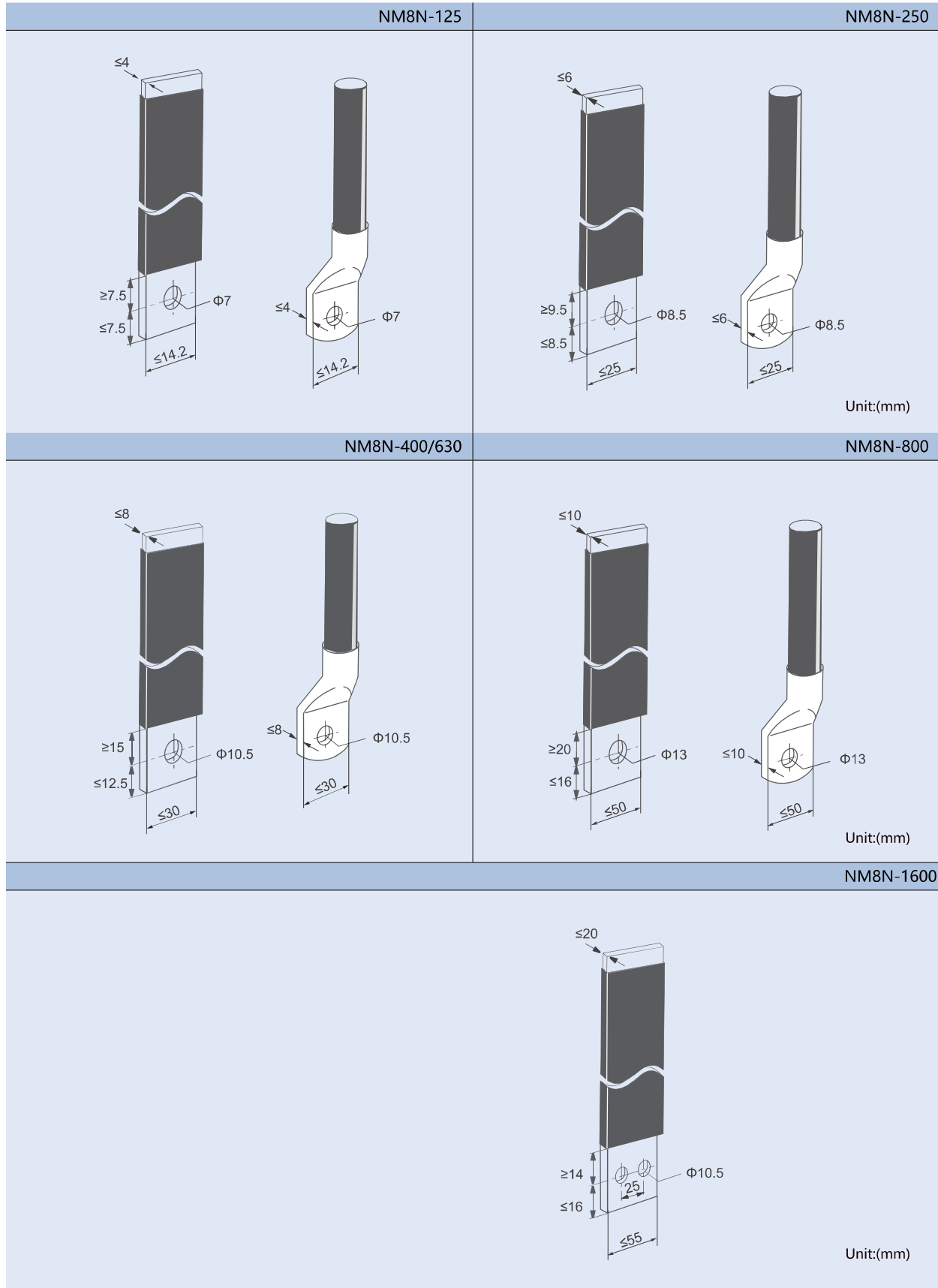

9 Accessories characteristics and installation

NM8N moulded case circuit breaker has various accessory modules, which can be found in P84 for more details

9.1 AX Auxiliary contact

9.1.1 Function

Remotely indicate the circuit breaker's making (on) or breaking / tripping (OFF) status, connected to the auxiliary circuit of the circuit breaker.

9.1.2 Model description



AX 21-M8

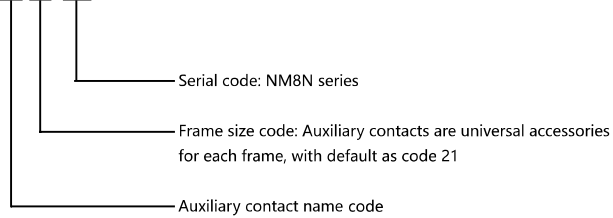

9.1.3 Indication of circuit breaker status

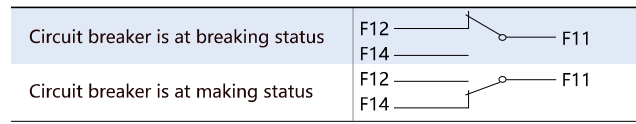

9.1.4 Electrical characteristics

Rated voltage (V)	Rated current (A)	
	AC-15	DC-13
AC 110	5	—
AC 240	4	—
AC 415	2	—
DC 110	—	0.25
DC 220	—	0.25

9.1.5 Wiring diagram

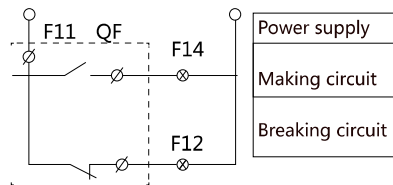



9.2 AL Alarm contact

9.2.1 Function

It is mainly used to provide a signal when the load of the circuit breaker is overloaded, short-circuited or undervoltage, or tripped.

The reasons for the failure of the alarm signal are:

- Over-load or short-circuit
- Undervoltage trip
- Residual current action trip
- Manual free trip

9.2.2 Model description

AL 21-M8

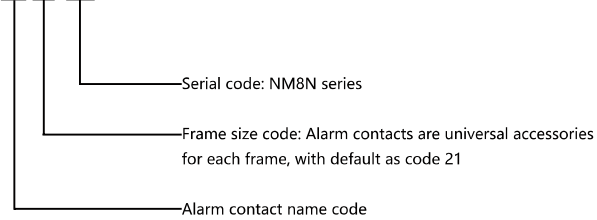

9.2.3 Indication of circuit breaker status

Circuit breaker is at breaking or making status	B12		B11
Circuit breaker is at free tripping status	B12		B11

9.2.4 Electrical characteristics

Rated voltage(V)	Rated current(A)	
	AC-15	DC-13
AC 110	5	—
AC 240	4	—
AC 415	2	—
DC 110	—	0.25
DC 220	—	0.25

9.2.5 Wiring diagram

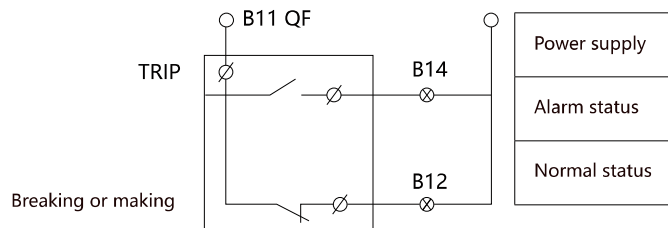



9.3 SHT Shunt release

9.3.1 Function

Shunt releases operate according to electrical signals, enabling remote control and automatic control of circuit breakers. When the supply voltage is equal to any voltage between 70% and 110% of the rated control power supply voltage, the shunt release should enable the circuit breaker to operate reliably.

9.3.2 Model description

SHT 21-M8 AC48V

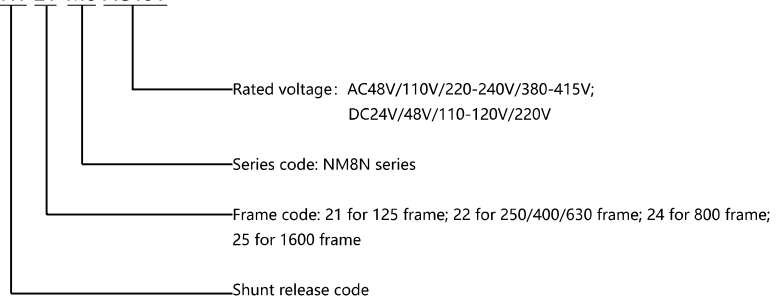

9.3.3 Electrical characteristics

Frame size	Power consumption (W)						
	AC48V	AC110V	AC220-240V	AC380-415V	DC24V	DC48V	DC220V
125A	2.2	2.2	2	2.5	2.5	2.2	2
250/400/630A	2.3	2.5	2.2	2.5	2.2	2.5	2.5
800A	2.3	2.5	2.2	2.5	2.2	2.5	2.5
1600A	110	195	480	560	230	110	160

9.3.4 Action characteristics

Can be powered for a long time. Response time: pulse type $\geq 20\text{ms}$, $\leq 60\text{ms}$

9.3.5 Wiring diagram

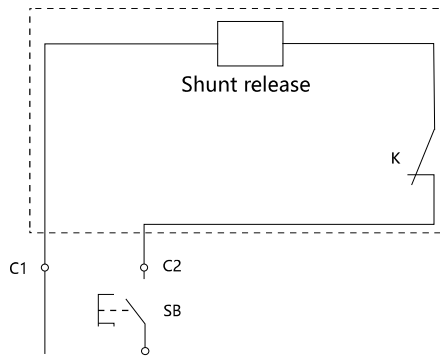

Note: When the rated control power supply voltage DC24V shunt release is used, the maximum length of the copper wire (each of the two wires) must meet the following table:

Rated control supply voltage U_s (DC24V)	Conductor cross-sectional area	
	1.5mm ²	2.5mm ²
100% U_s	150m	250m
85% U_s	100m	160m

9.4 UVT Under-voltage release



9.4.1 Function

Realize the under-voltage protection function of the circuit breaker, open the circuit breaker when the power supply voltage is too low, and protect the electrical equipment.

- When the supply voltage drops (even slowly) to 70% to 35% of the rated control supply voltage, the undervoltage trips. The breaker should open the circuit breaker reliably.
- When the supply voltage is equal to or greater than 85% of the rated control supply voltage of the undervoltage release, the circuit breaker should be guaranteed to close.
- When the supply voltage is less than 35% of the rated control supply voltage of the undervoltage release, the undervoltage release should prevent the circuit breaker.

9.4.2 Model description

UVT 21-M8 AC48V

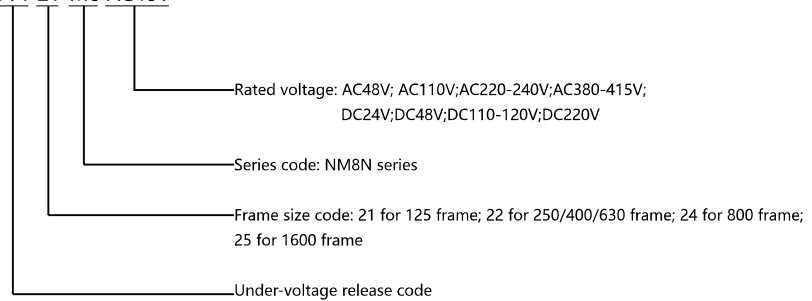

9.4.3 Electrical characteristics

Frame size	Power consumption (W)							
	AC48V	AC110V	AC220-240V	AC380-415V	DC24V	DC48V	DC110-120V	DC220V
125A	1.6	1.6	2	3	1.2	1.6	2	2.2
250/400/630A	1.5	1.5	2.2	3	0.8	1.5	2	2.5
800A	1.5	1.5	2.2	3	0.8	1.5	2	2.5
1600A	2.6	2.2	1.7	0.7	2.8	2.5	2.2	1.8

9.4.4 Wiring diagram

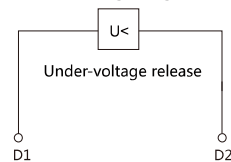



9.5 MOD Motor-driven mechanism

9.5.1 Function

It is suitable for closing, opening and re-opening of circuit breakers at long distances, as well as automation applications.

A: Protection level: IP40

- Reliable insulation;
- With isolation function indication;
- O (open), I (closed) and free trip 3 position indications;
- Free circuit breaker trip;
- Manually or automatically operated circuit breakers for closing and opening.

B: manual operation

Pull the "manual / auto" switch to the manual position and turn the operation handle to switch on and off the circuit breaker.

C: automatic operation

Pull the "manual / auto" switch to the automatic position, and remotely press the "close or open" button to switch on and off the circuit breaker.

D: Automatically switch on or off by pulse or self-holding signal control.

E: Only when the control voltage is $\geq 85\% U_n$ and $\leq 110\% U_n$ can the circuit breaker be reliably switched on and off.

9.5.2 Model description

MOD 21-M8 AC110/DC110-120V

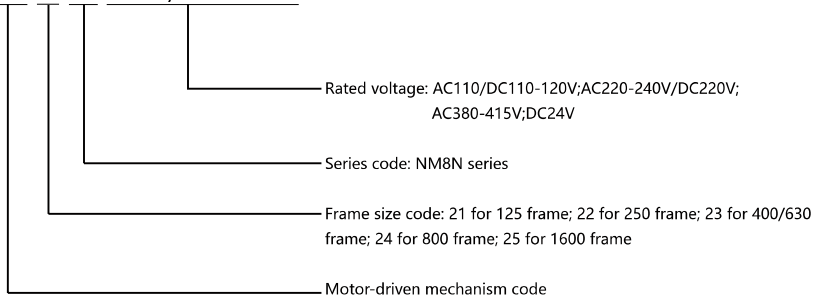

Note: The 1600 frame motor-driven mechanism is assembled in the factory and is suitable for electronic circuit breakers and disconnectors according to the inside of the circuit breaker.

9.5.3 Electrical characteristics

9.5.3 Electrical characteristics

Frame size	Operational Type	Rated operational voltage	Life (CO recycle)	Power consumption	Action current	Making duration	Breaking duration	Minimum duration of ON(OFF) signal pulse
125A	MOD 21-M8	AC110V/DC110	10000	150	≥ 3	≤ 500ms	≤ 500ms	300ms
		AC220-240V		150	≥ 4			
250A	MOD 22-M8	DC220V	10000	150	≥ 3	≤ 500ms	≤ 500ms	300ms
		AC380-415V		150	≥ 4			
400/630A	MOD 2-M8	DC24V	8000	100	≥ 3	≤ 1000ms	≤ 1000ms	300ms
		AC110V/DC110		300	≥ 8			
800A	MOD 23-M8	AC220-240V	4000	300	≥ 3	≤ 1000ms	≤ 1000ms	300ms
		DC220V		300	≥ 8			
		AC380-415V		300	≥ 3			
		DC24V		190	≥ 8			



9.5.4 Wiring diagram

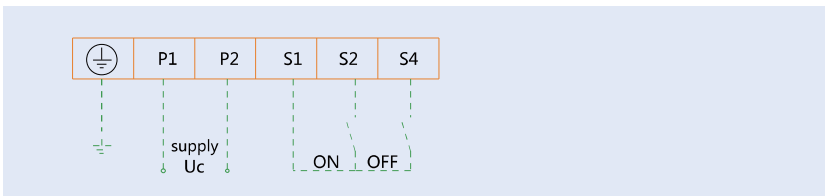

9.5.5 Installation dimension drawing

Overall and mounting dimension of MOD21-M8

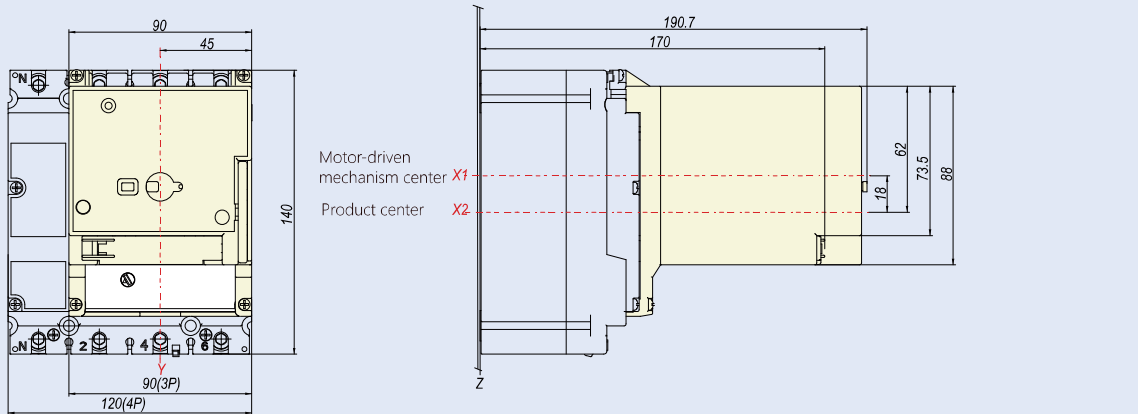
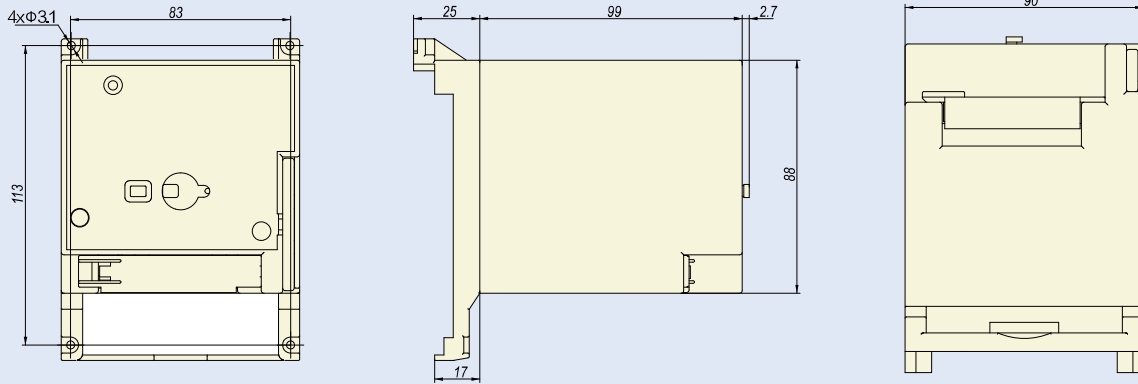

Overall dimension of MOD22-M8

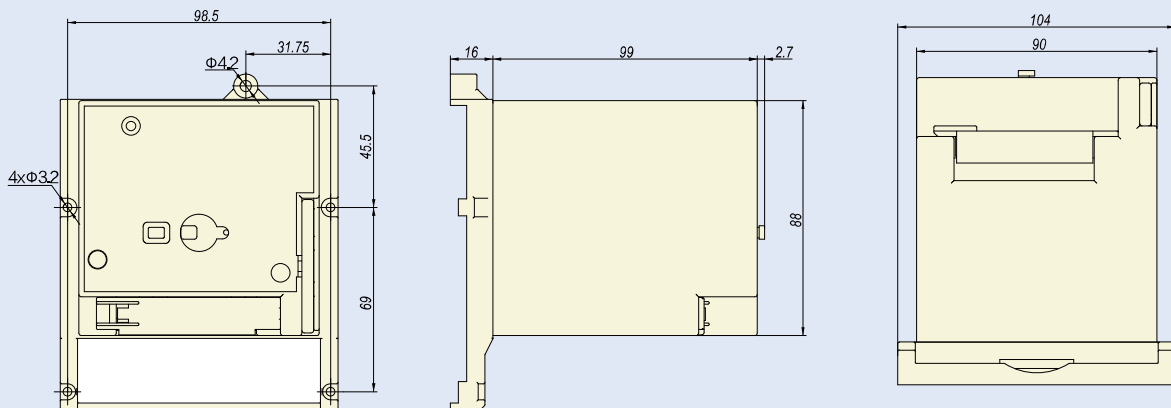



Mounting dimension of MOD22-M8

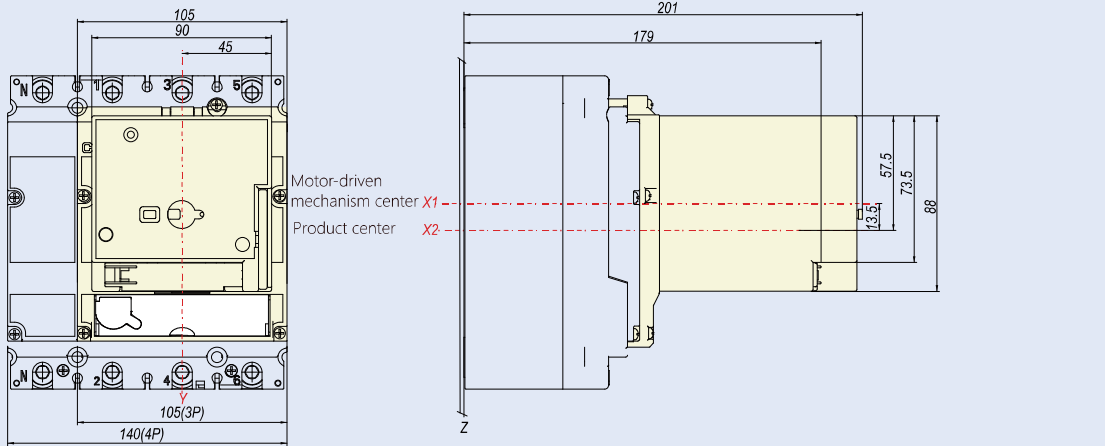

Overall and mounting dimension of MOD23-M8

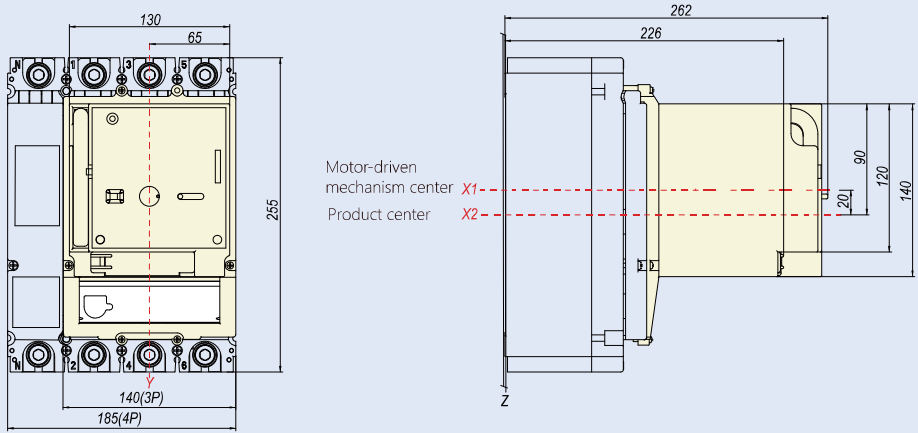
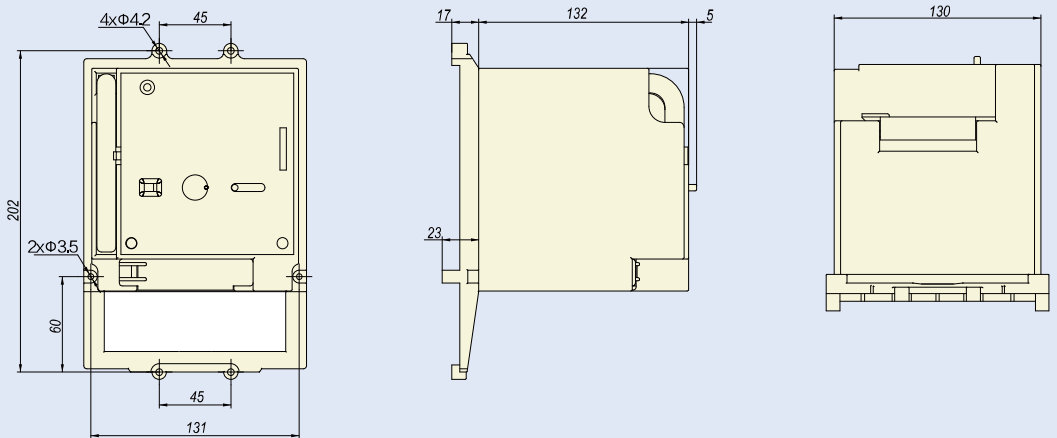

Overall and mounting dimension of MOD24-M8

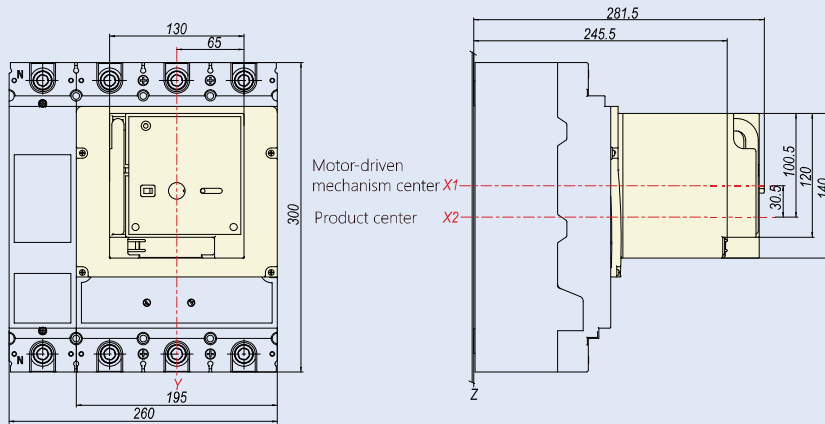
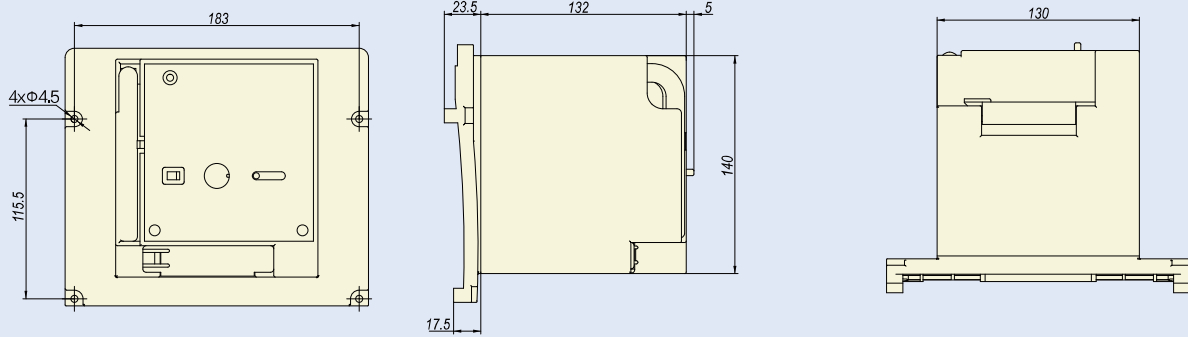



9.6 SRH Economic extended rotary handle

9.6.1 Function

The unique design and transmission structure are adopted to realize the closing, opening and re-closing operation of the circuit breaker by rotating the handle.

Protection degree: IP30

- With isolation function indication;
- O (open), I (closed) and free trip 3 position indications;
- The circuit breaker can be locked in the OFF position with 1 ~ 3 padlocks with a diameter of 5 ~ 8mm. At this time, it can prevent the circuit breaker from closing and the switch cabinet from opening;
- When the switch is in the ON position, the cabinet door cannot be opened under the action of the rotary handle (if the cabinet door is opened urgently, the cabinet door can be opened by the emergency unlocking device on the handle).



9.6.2 Model description

SRH 21-M8 3P

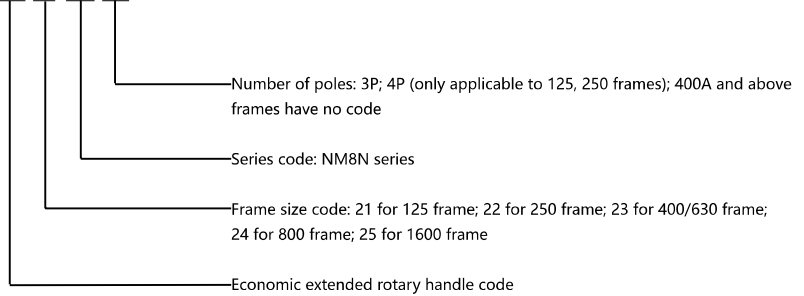

9.6.3 Installation dimension drawing

Overall and mounting dimension of SRH21-M8

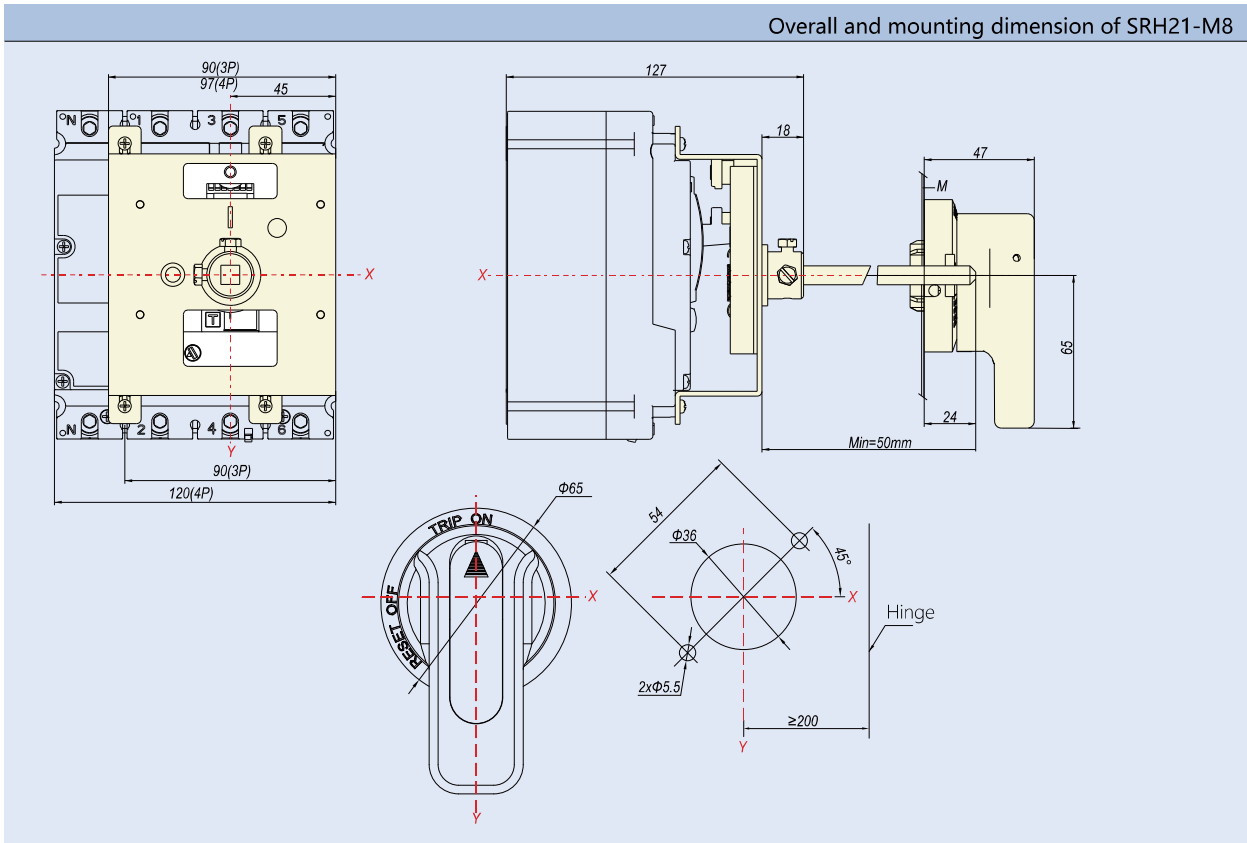

Overall and mounting dimension of SRH22-M8

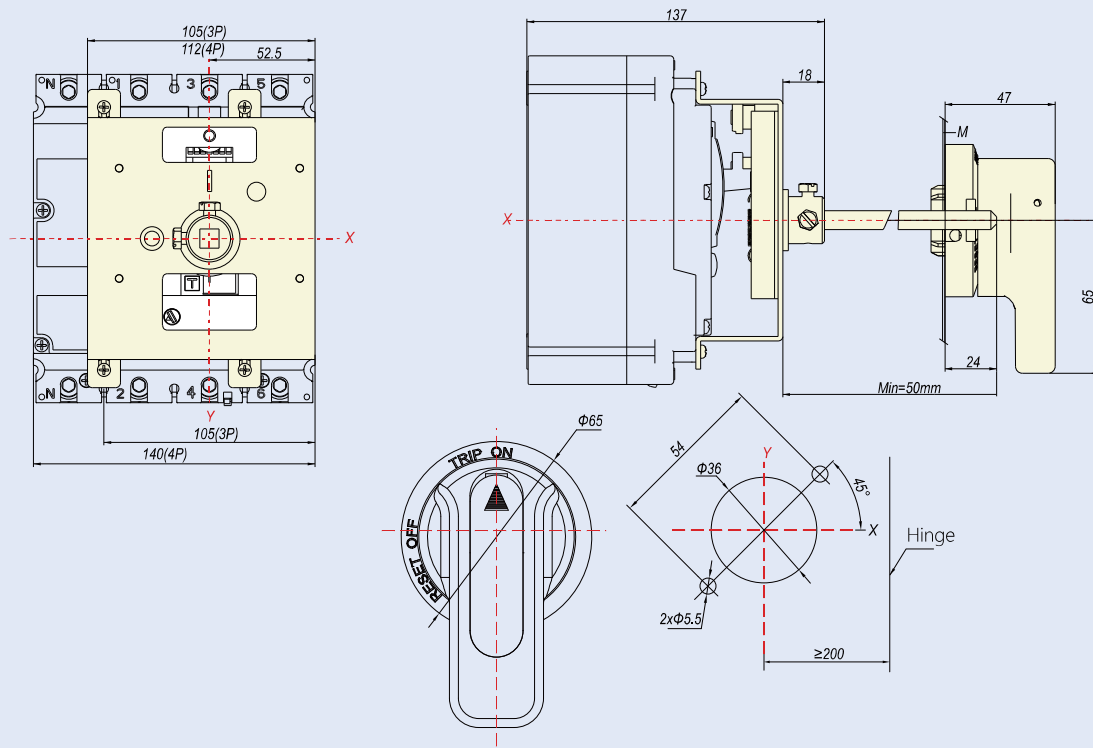

Overall and mounting dimension of SRH23-M8

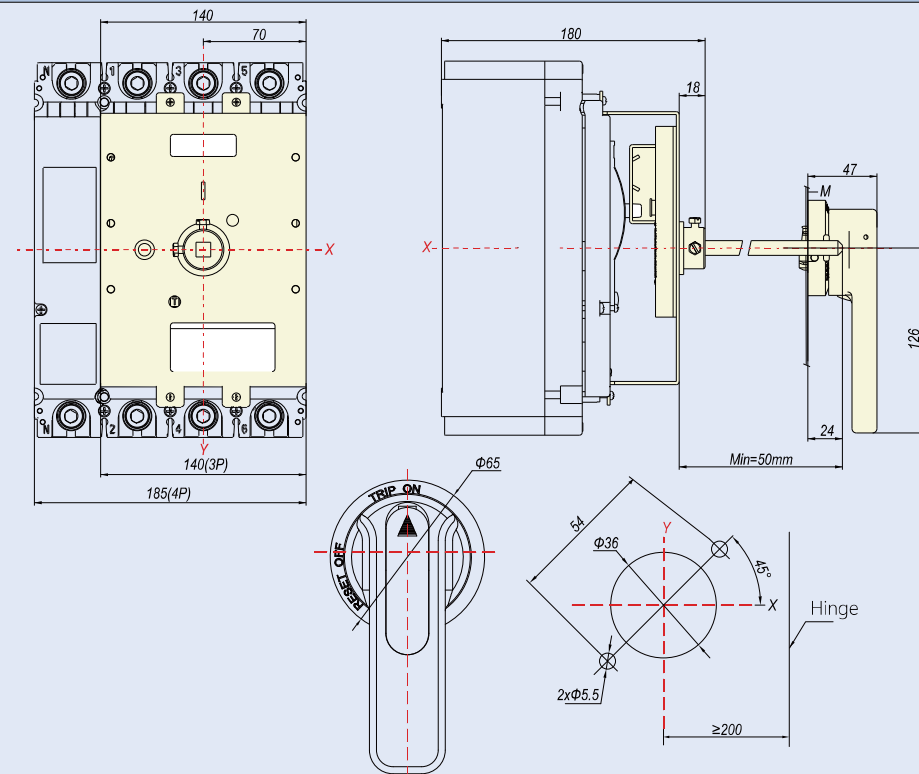

B

Overall and mounting dimension of SRH24-M8

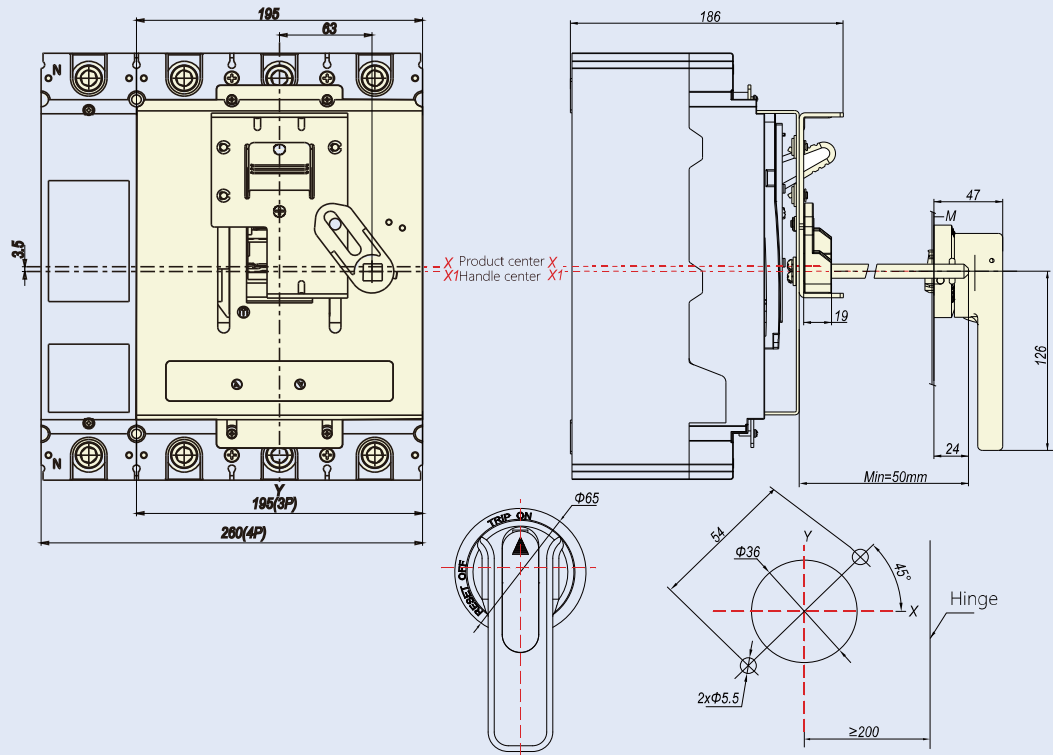

Overall and mounting dimension of SRH25-M8

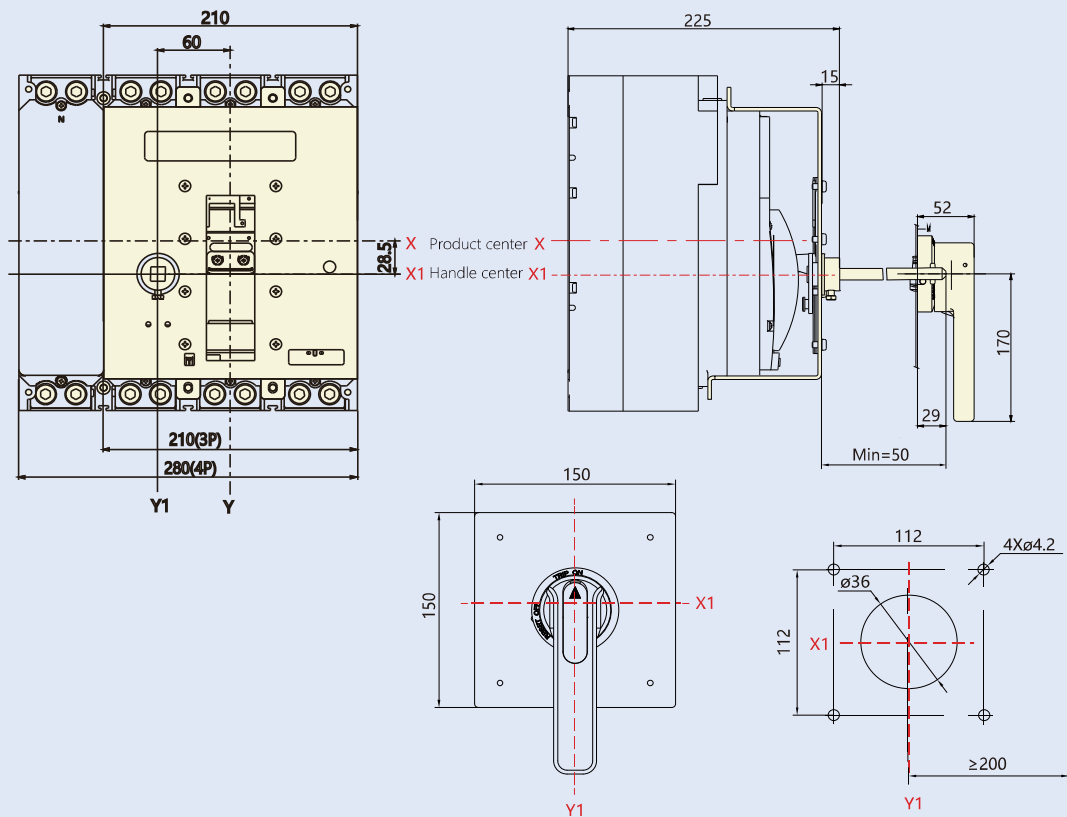

9.7 DRH Direct rotary handle

9.7.1 Function

The unique design and transmission structure are adopted to realize the closing, opening and re-closing operation of the circuit breaker by rotating the handle.

Protection degree: IP40

- Reliable insulation;
- With isolation function indication;
- O (open), I (closed) and free trip 3 position indications;
- The circuit breaker can be locked in the OFF position through 1~3 padlocks with a diameter of 5 ~ 8mm.
- (Padlock user prepared)



9.7.2 Model description

DRH 21-M8 T

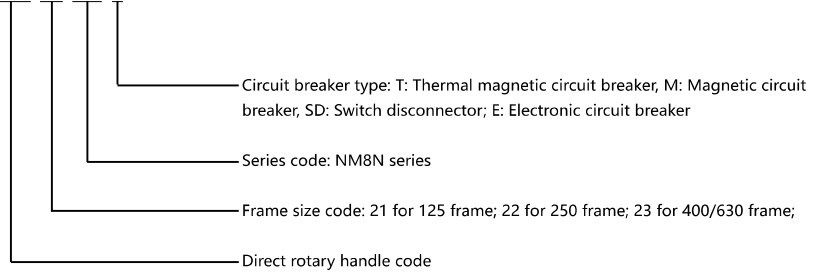

9.7.3 Installation dimension drawing

Overall dimension of DRH21-M8

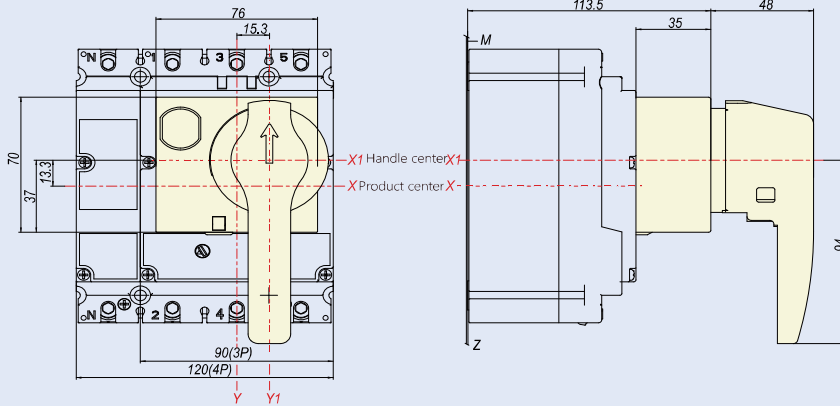

Overall dimension of DRH22-M8

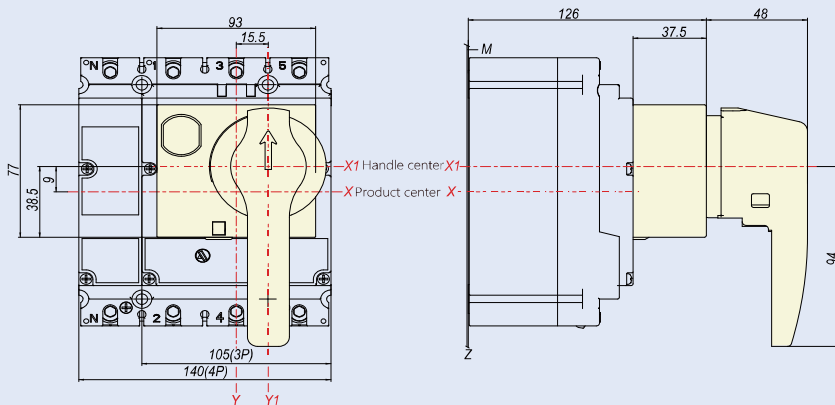

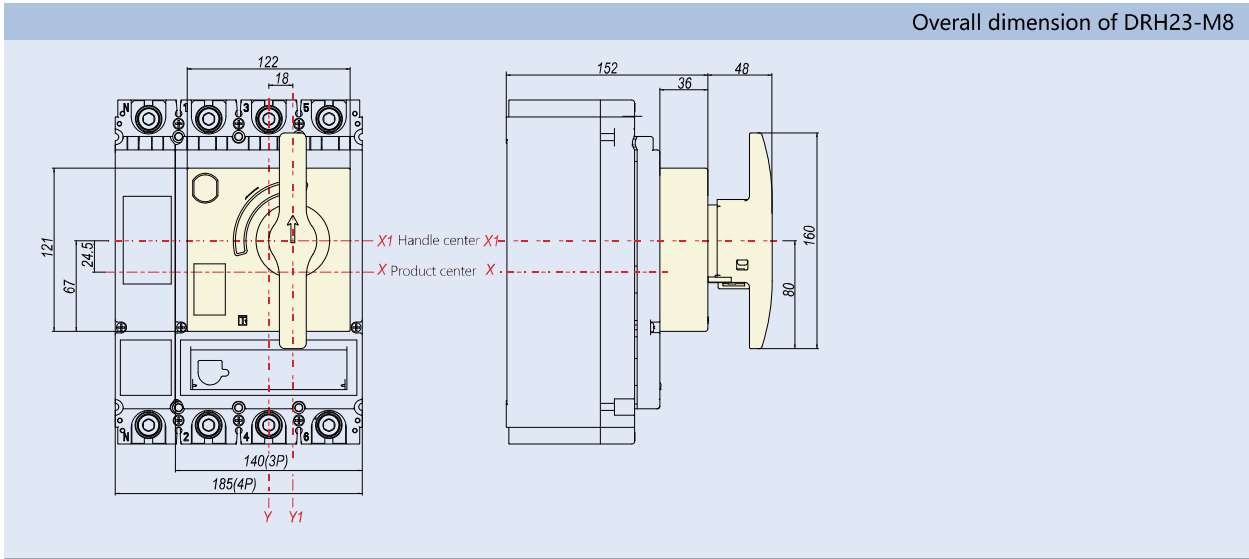

9.8 ERH Extended rotary handle

9.8.1 Function

The unique design and transmission structure are adopted to realize the closing, opening and re-closing operation of the circuit breaker by rotating the handle.

Protection degree: IP50

- Reliable insulation;
- With isolation function indication;
- O (open), I (closed) and free trip 3 position indications;
- When the switch cabinet door is open, the setting value of the circuit breaker release can be set;
- When the switch cabinet door is opened, it can prevent the circuit breaker from closing;
- The circuit breaker can be locked in the OFF position through (1 ~ 3) padlocks with a diameter of (5 ~ 8) mm;
- (Padlock user prepared) can prevent the switch cabinet door from opening at this time;
- When the switch is in the ON position, the cabinet door cannot be opened under the action of the rotary handle (if the cabinet door is opened urgently, the cabinet door can be opened by the emergency unlocking device on the handle).

9.8.2 Model description

ERH 21-M8 T

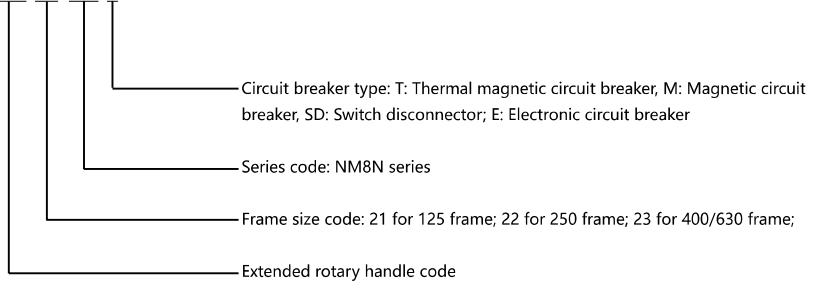

9.8.3 Installation dimension drawing

Overall and mounting dimension of ERH21-M8

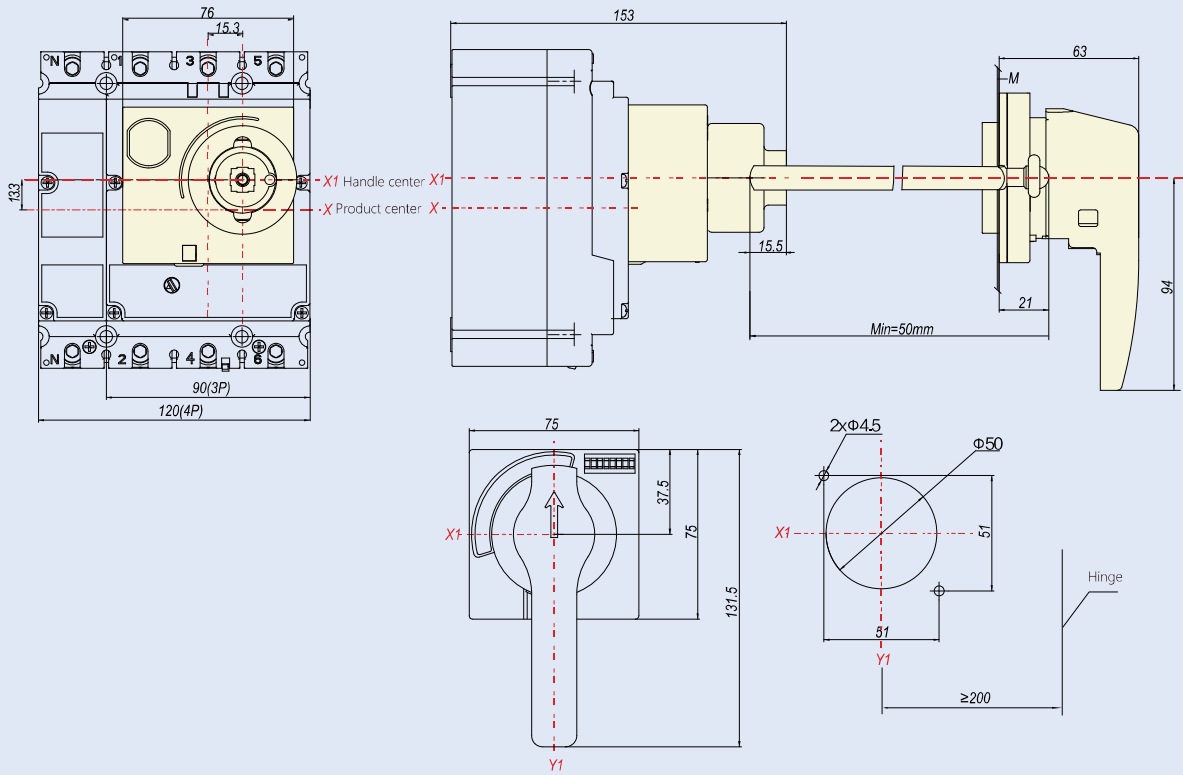

Overall and mounting dimension of ERH22-M8

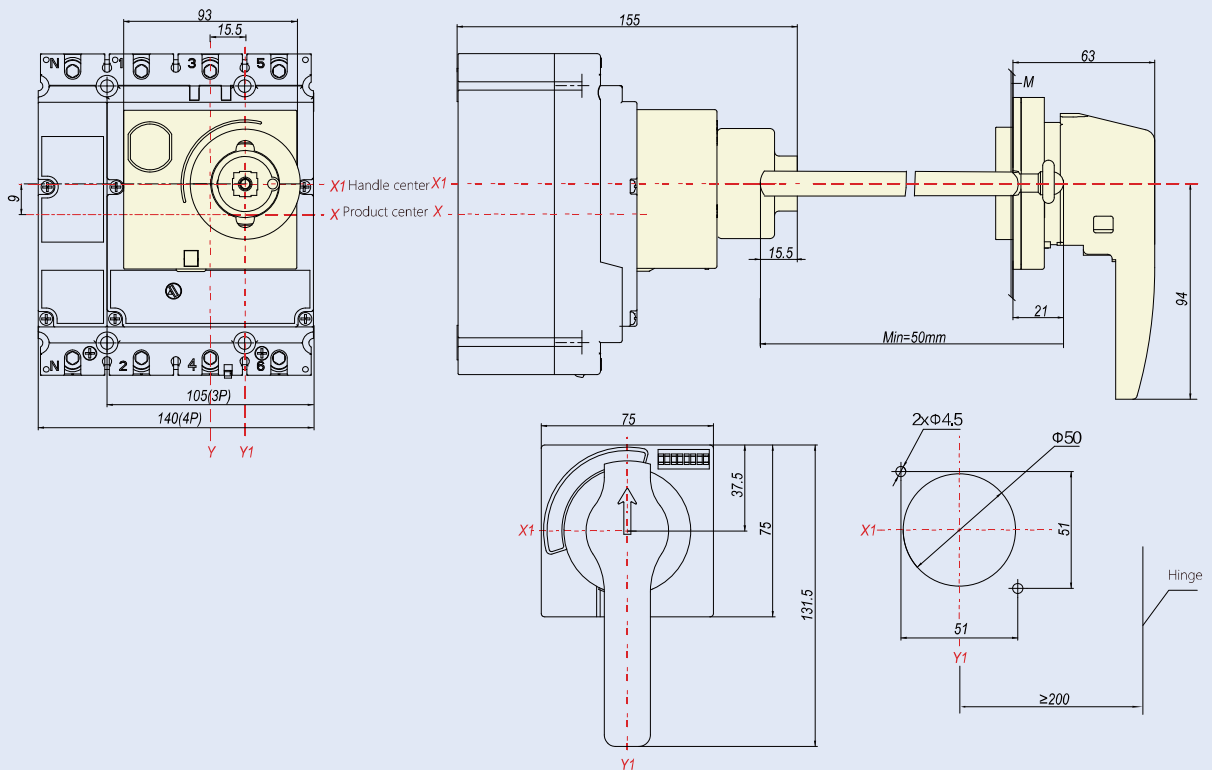

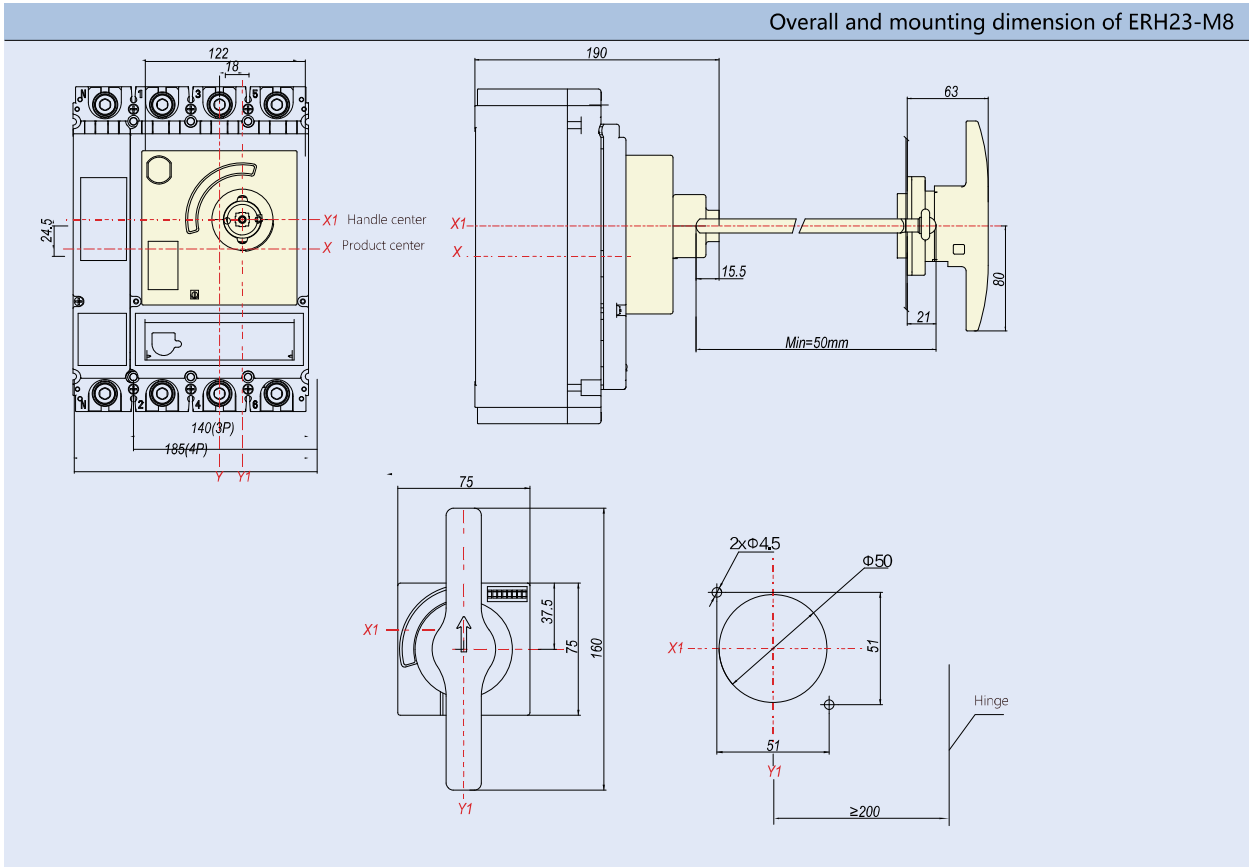

9.9 LHD Extended handle

9.9.1 Function

With a unique design, the circuit breaker can be closed, opened and re-latched by rotating the handle. It is only applicable to 1600A.

9.9.2 Model description

LHD 25-M8

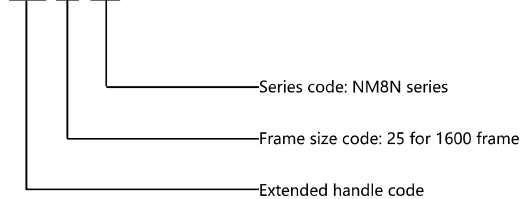

9.9.3 Overall dimension

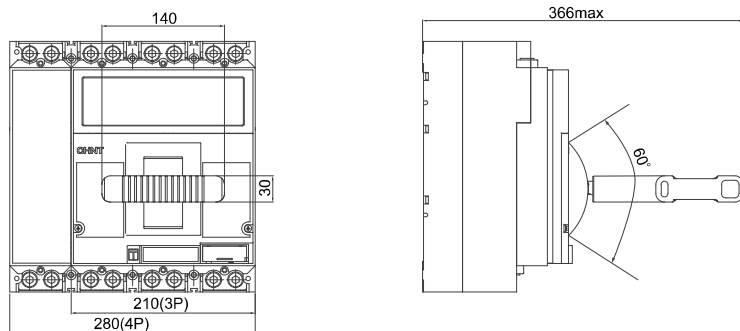

9.10 KLK Locking system

9.10.1 Function

The locking system locks the open position of the circuit breaker.

- The locking system can be equipped with (1 ~ 3) padlocks with a diameter range (5 ~ 8) mm.
- (Padlock user prepared))



9.10.2 Model description

KLK 21-M8

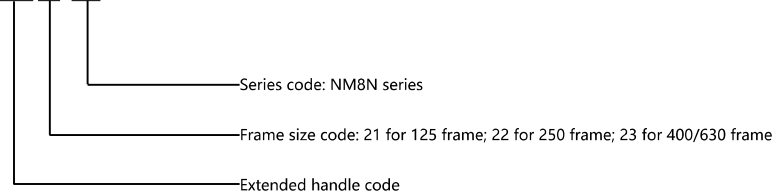

9.11 MIT Mechanical interlock

9.11.1 Function

When used together with two circuit breakers with the same housing, when one circuit breaker is closed, the other circuit breaker cannot be closed and is in the open state.



9.11.2 Model description

MIT 21-M8 3P

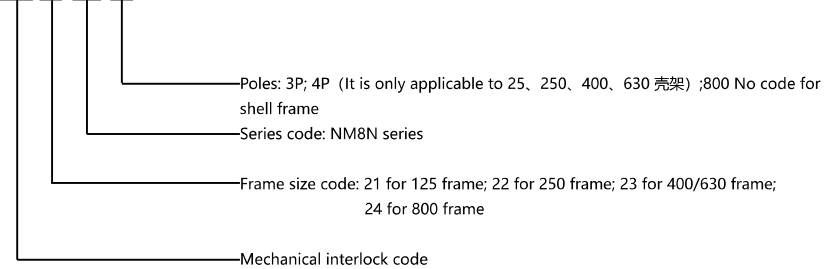

9.12 TCV Short terminal cover

9.12.1 Function

Prevents contact with the main circuit and can also be used to prevent short circuit between phases.

Protection degree: IP40

For voltages $\geq 500V$, terminal covers must be fitted



9.12.2 Model description

TCV 21-M8 3P

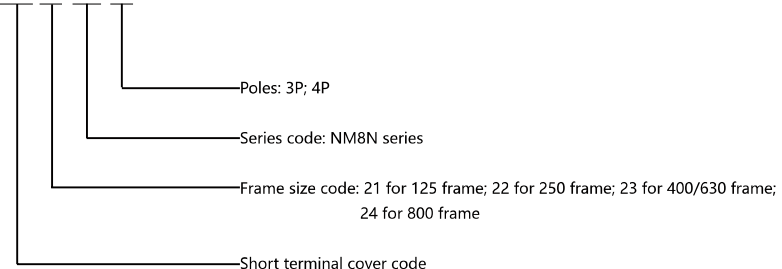



9.13 TCE Long terminal cover



9.13.1 Function

Prevents contact with the main circuit and can also be used to prevent short circuit between phases. There are knock-out holes in front of the terminal cover to accommodate various lug cables and front wiring.

Protection degree: IP40

For voltages $\geq 500V$, terminal covers must be fitted

9.13.2 Model description

TCE 21-M8 3P

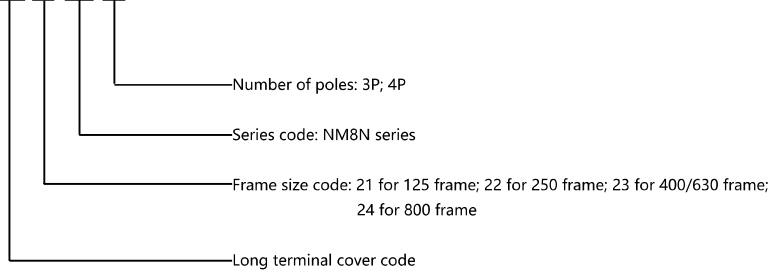

9.14 FCP Front connection plate



9.14.1 Function

Make the circuit breaker have a flexible wiring mode. By installing this accessory, the pole spacing can be increased to increase the electrical gap between adjacent poles at the inlet and outlet ends of the circuit breaker and enhance the safety between lines.

9.14.2 Model description

FCP 25-M8 3P(1600¹⁾)

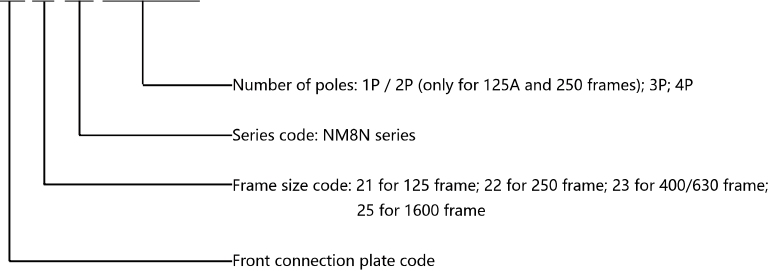

Note¹⁾: Only applicable to 1600 frame, there are three specifications of 1000, 1250, 1600

9.15 RCP Rear connection plate



9.15.1 Function

Make the circuit breaker have flexible wiring mode, which can realize the wiring behind the board

9.15.2 Model description

RCP 21-M8 2P

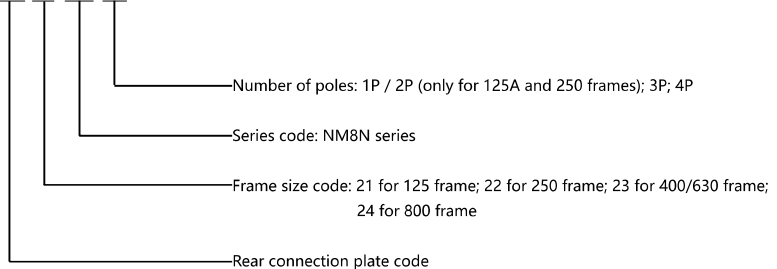

9.16 CCT Cage clamp terminal

9.16.1 Function

Make the circuit breaker have a flexible wiring mode, which can directly connect the bare wires.

9.16.2 Model description



CCT21/22-M8



CCT23-M8

CCT 21-M8

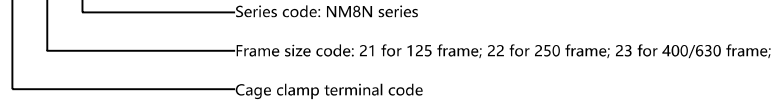

9.16.3 Wiring capacity

Serial No.	Wiring capacity	Torque
CCT21-M8	(2.5~75)mm ²	8N·m
CCT22-M8	(10~120)mm ²	10N·m
CCT23-M8	(120~240)mm ²	35N·m

9.17 MC Cable connector

9.17.1 Function

Make the circuit breaker have a flexible wiring method, which can directly connect the bare wires and realize the connection of multiple wires.

9.17.2 Model description



MC 25-M8(3)(1250¹⁾)

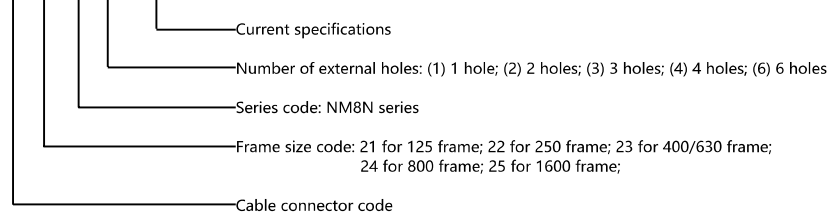

Note¹⁾ : Only applicable to 1600 housing, only 800-1250 specifications

9.17.3 Wiring capacity

Serial No.	Wiring capacity	Torque	Note
MC21-M8 (1)	(16~95)mm ²	10N·m	1hole
MC22-M8 (1)	(35~240)mm ²	30N·m	1hole
MC22-M8 (2)	2x(35~120)mm ²	30N·m	2holes
MC22-M8 (6)	6x(10~35)mm ²	10N·m	6holes
MC23-M8 (2)	2x(120~240)mm ²	35N·m	2holes
MC23-M8 (4)	4x95mm ²	15N·m	4holes
MC24-M8 (2)	2x240mm ²	35N·m	2holes
MC25-M8(800) (3)	3x(95~300)mm ²	35N·m	3holes
MC25-M8(1000/1250) (4)	4x(95~240)mm ²	35N·m	4holes

9.18 PIA Plug-in base

9.18.1 Function

- Quickly change the circuit breaker without changing the inlet and outlet wires and installing the base;
- Plug-in base can be pre-installed, which is convenient for customers to add circuit breakers in the future;
- When the circuit breaker is installed through the board or the base, the power circuit can be isolated;
- With plug-in safety device function (optional), it can ensure that the circuit breaker can trip automatically when it is pulled out when the circuit breaker is closed.



9.18.2 Model description

PIA 21F-M8 3P

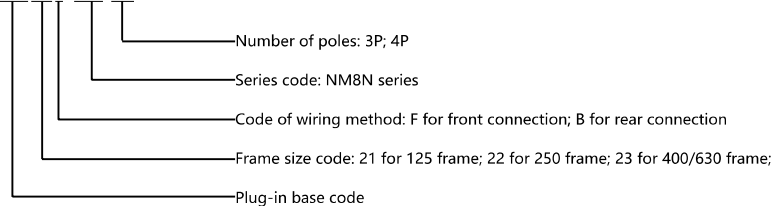



9.19 PISD Plug-in safety device



9.1 Function

Used together with the plug-in base, it can ensure that the circuit breaker can automatically trip when it is pulled out when the circuit breaker is closed.

9.2 Model description

PISD 21-M8 T

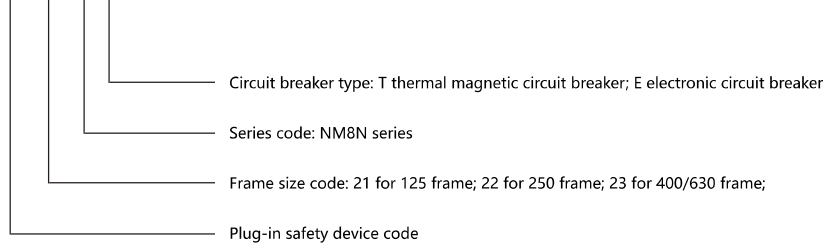

9.20 DOB Draw-out base

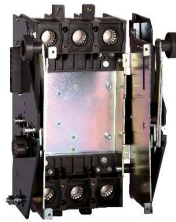

9.20.1 Function

- Quickly change the circuit breaker without changing the inlet and outlet wires and installing the base;
- Withdrawable base can be installed in advance to provide convenience for customers to add circuit breakers later;
- With plug-in safety device function (optional), it can ensure that the circuit breaker can automatically trip when it is pulled out when the circuit breaker is closed.

9.20.2 Model description

DOB 23F-M8 3P(400A)¹⁾

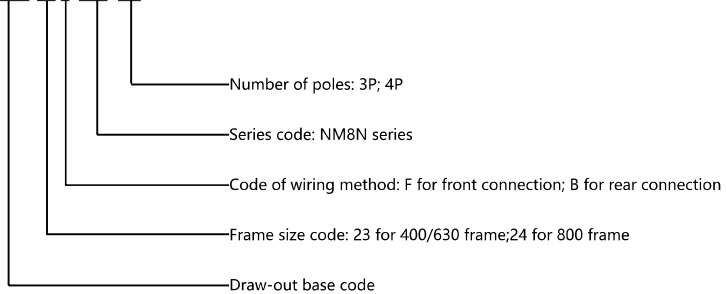

Note¹⁾: DOB23 is suitable for 400/630 housings. There are two specifications of 400 and 630.

9.21 DOSD Draw-out safety device



9.21.1 Function

Used together with the plug-in base, it can ensure that the circuit breaker can automatically trip when it is pulled out when the circuit breaker is closed.

9.21.2 Model description DOSD 23-M8 T

DOSD 23- M8 T

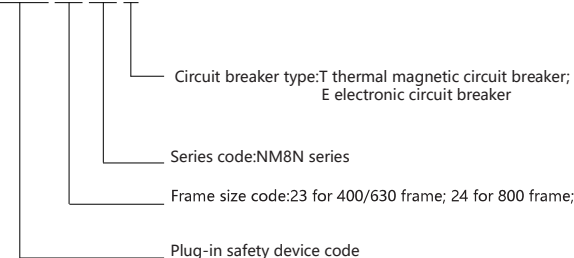

Note¹⁾: This accessory is pre-mounted with DOB, do not need to order.

9.22 DRA DIN-rail adapter

9.22.1 Function

Adapt to the body and can be mounted on a 35mm standard DIN rail



9.22.2 Model description

DRA 21-M8 3P

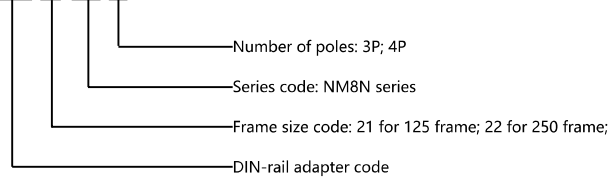

9.23 COMA communication module

9.23.1 Function

The COMA communication module is an interface module for the communication between the electronic plastic case circuit breaker and the bus system, and performs communication and relay control output. Combined with the Modbus-RTU communication protocol, this communication module can easily establish a connection with a fieldbus master device to achieve three remote or four remote functions.

The technical parameters are as follows:

- Rated voltage: AC230V or DC24V (error range $\pm 15\%$)
- Communication type: RS485 (Modbus-RTU protocol)
- Contact capacity: AC250V / 3A; DC30V / 3A
- Transmission medium: shielded twisted pair
- Transmission distance: 1.2km (using category A shielded twisted pair)
- Working status indication: LED indication
- Number of stations: 1 station



9.23.2 Model description

COMA22-M8 DC24V 0.5m

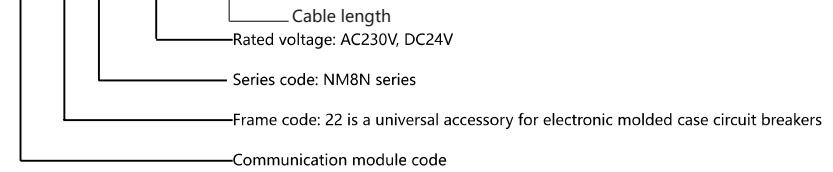

9.23.3 Communication solution

Solutions	Achievable function	Required products and accessories	Note
Solution 1	Remote measure	NM8N basic or standard electronic molded case circuit breaker; COMA22-M8 communication module.	1. Read phase current
Solution 2	Remote measure Remote signal	NM8N basic or standard electronic moulded case circuit breaker; COMA22-M8 communication module; AX auxiliary contact (optional, indicating opening and closing status); AL alarm contact (optional, indicating trip status).	1. Read phase current 2. Indicate circuit breaker position information (open, closed, trip status)
Solution 3	Remote measure Remote signal Remote control	NM8N basic or standard electronic moulded case circuit breaker; COMA22-M8 communication module; AX auxiliary contact (optional, indicating opening and closing status); AL alarm contact (optional, indicating trip status); MOD electric operation mechanism.	1. Read phase current 2. Indicate circuit breaker position information (open, closed, trip status) 3. Control circuit breaker opening and closing
Solution 4	Remote measure Remote signal Remote control Remote adjustment	NM8N standard electronic molded case circuit breaker; COMA22-M8 communication module; AX auxiliary contact (optional, indicating opening and closing status); AL alarm contact (optional, indicating trip status); MOD electric operation mechanism.	1. Read phase current 2. Indicate circuit breaker position information (open, closed, trip status) 3. Control circuit breaker opening and closing 4. Adjust the internal parameter settings of the controller (only for standard specifications. For details, please refer to the communication protocol).



9.24 PSU battery box



9.24.1 Function

Provide DC 9V power for the standard (liquid crystal) controller for users to view, set and modify controller parameters.,when current under 0.4In.The batteries inside box are changeble.

Output voltage: DC 9V

Continuous power supply time: 7 hours

9.24.2 Model description

PSU22-M8

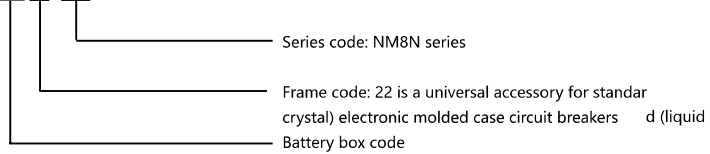

9.25 PHS Phase barrier

9.26.1 Function

Guarantees phase-to-phase insulation safety and prevents phase-to-phase short circuits

9.26.2 Model description

PHS 21-M8

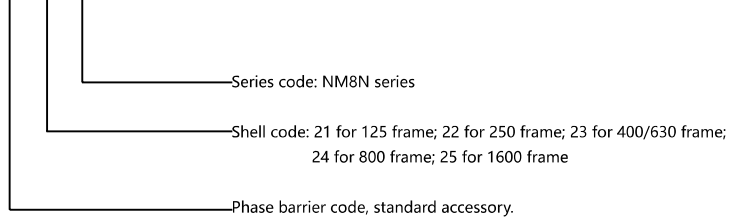

9.26 Installation diagram of internal accessories

Accessory name	Mounting and wiring mode				
	NM8N-125, 250 NM8NL-125, 250	NM8N-400, 630 NM8NL-400, 630	NM8N-800	NM8N-1600	NM8N-1600 MOD
	3P, 4P	3P, 4P	3P, 4P	3P, 4P	3P, 4P
No accessory					
Alarm contact					
Auxiliary contact					
Shunt release					
Under-voltage release					
Shunt release Auxiliary contact					
Auxiliary contact Under-voltage release					
Shunt release Alarm contact					
Auxiliary contact Alarm contact					
Under-voltage release Alarm contact					
Shunt release Auxiliary contact, alarm					
Auxiliary contact alarm contact Under-voltage release					

■-Shunt release ▲-Under-voltage release ○-Auxiliary contact ●-Alarm contact

Note: a. NM8N-125, 250, 400, 630, 800 cannot be equipped with undervoltage release and shunt release at the same time;

b. NM8N-125, 250 3P / 4P can be equipped with a maximum of 2 sets of auxiliary contacts; 1P has no internal accessories; 2P can be equipped with a maximum of one auxiliary / alarm contact at the same time;

c. NM8N-400, 630 can install up to 3 sets of auxiliary contacts;

d. NM8N-800 can be equipped with up to 4 auxiliary contacts;

e. NM8N-1600 MOD can be equipped with a maximum of 3 sets of auxiliary contacts, and can simultaneously install undervoltage release and shunt release;

f. NM8N series can only be equipped with one alarm contact.

10 Technical Supplement

10.1 DC application wiring method

B

Solutions	Unipolar grounding system	Ungrounded system												
Circuit diagram														
Impact of fault	<table border="1" style="width: 100%; border-collapse: collapse;"> <tr> <td style="width: 20%;">Fault A</td> <td>maximum short-circuit current I_{sc}</td> </tr> <tr> <td>Fault B</td> <td>maximum short-circuit current I_{sc}</td> </tr> <tr> <td>Fault C</td> <td>has no effect</td> </tr> </table>	Fault A	maximum short-circuit current I_{sc}	Fault B	maximum short-circuit current I_{sc}	Fault C	has no effect	<table border="1" style="width: 100%; border-collapse: collapse;"> <tr> <td style="width: 20%;">Fault A</td> <td>has no effect</td> </tr> <tr> <td>Fault B</td> <td>maximum short-circuit current I_{sc}</td> </tr> <tr> <td>Fault C</td> <td>has no effect</td> </tr> </table>	Fault A	has no effect	Fault B	maximum short-circuit current I_{sc}	Fault C	has no effect
Fault A	maximum short-circuit current I_{sc}													
Fault B	maximum short-circuit current I_{sc}													
Fault C	has no effect													
Fault A	has no effect													
Fault B	maximum short-circuit current I_{sc}													
Fault C	has no effect													
\leq DC500V	<p>Note: 1. The upper and lower lines can be used, here the following lines are taken as an example.</p>	<p>Note: 1. Both the upper and lower lines can be used, here the following lines are taken as an example; 2. Make sure that the installation method does not cause a secondary ground fault.</p>												
DC500~750V	<p>Note: 1. The upper and lower lines can be used, here the following lines are taken as an example.</p>	<p>Note: 1. Both the upper and lower lines can be used, here the following lines are taken as an example; 2. Make sure that the installation method does not cause a secondary ground fault.</p>												
DC750~1000V	<p>Note: 1. The upper and lower lines can be used, here the following lines are taken as an example.</p>													

10.2 NM8N power loss table

Release type	Model	Rated current (A)	Fixed circuit breaker resistance loss per pole mΩ	Power loss per pole (W)
Thermal magnetic	NM8N-125	16	8.8	2.3
		20	8.8	3.5
		25	5.2	3.3
		32	4.5	4.6
		40	2.6	4.2
		50	1.8	4.5
		63	1.7	6.7
		80	1.3	8.3
		100	0.88	8.8
	125	0.8	12.5	
	NM8N-250	125	0.7	10.9
		160	0.55	14.1
		180	0.55	17.8
		200	0.55	22.0
		225	0.4	20.3
	NM8N-400	250	0.35	21.9
		315	0.25	24.8
		350	0.25	30.6
		400	0.15	24.0
	NM8N-630	400	0.15	24.0
		500	0.12	30.0
	NM8N-800	500	0.08	20.0
		630	0.08	31.8
		700	0.08	39.2
		800	0.08	51.2
	NM8N-1600	800	0.08	51.2
		1000	0.08	80.0
		1250	0.04	62.5
1600		0.04	102.4	
Electronic	NM8N-250	32	0.8	0.8
		63	0.4	1.6
		100	0.4	4.0
		160	0.4	10.2
		250	0.4	25.0
	NM8N-400	250	0.15	9.4
		400	0.15	24.0
	NM8N-630	400	0.15	24.0
		630	0.12	47.6
	NM8N-800	800	0.08	51.2
	NM8N-1600	800	0.08	51.2
		1000	0.08	80.0
		1250	0.04	62.5
1600		0.04	102.4	
Switch disconnect	NM8NSD-125	63	0.8	3.2
		100	0.8	8.0
		125	0.8	12.5
	NM8NSD-250	125	0.4	6.3
		160	0.4	10.2
		200	0.4	16.0
		250	0.4	25.0
	NM8NSD-400	250	0.15	9.4
		400	0.15	24.0
	NM8NSD-630	630	0.12	47.6
	NM8NSD-800	800	0.08	51.2

10.3 NM8N thermal magnetic circuit breaker rated operational current and temperature compensation coefficient table

Rated current		Ambient temperature	-40°C	-35°C	-25°C	-15°C	-5°C	0°C	+10°C	+20°C	+30°C	+40°C	+50°C	+60°C	+70°C
NM8N-125	16A	22.5	22	20.5	20	19.5	19	18.5	17.5	17	16	15	14.5	14	
	20A	28	27.5	26.5	25.5	24.5	24	23	22	21	20	19.5	18.5	18	
	25A	35	34	33	32	30.5	30	28	27	26	25	24	22.5	22	
	32A	45	44	42	41	39	38	37	35	33	32	30.5	29	28	
	40A	56	55	53	51	49	48	46	44	42	40	37	33.5	29	
	50A	70	68.5	66	64	61	60	57.5	55	52.5	50	47.5	45	40	
	63A	88	86.5	83	80	77	75	72	69	66	63	58.5	53	46	
	80A	112	110	106	102	98	96	92	88	84	80	74.5	67	56	
	100A	140	137	132	127	122	120	115	110	105	100	93	84	80	
	125A	175	172	165	159	153	150	144	137	131	125	116	105	91	
NM8N-250	125A	175	172	165	159	153	150	144	137	131	125	118	106	96	
	160A	224	220	212	204	196	192	184	176	168	160	152	136	120	
	180A	252	247	238	229	220	216	207	198	189	180	171	157	144	
	200A	280	275	265	255	245	240	230	220	210	200	190	175	166	
	225A	315	309	300	288	276	270	259	247	236	225	213	196	180	
	250A	350	343	332	319	306	300	287	275	262	250	237	218	207	
NM8N-400	250A	350	343	332	319	306	300	287	275	262	250	237	225	212	
	315A	441	433	418	402	386	378	362	346	331	315	300	286	271	
	350A	490	481	465	447	429	420	402	385	367	350	332	295	276	
	400A	560	550	530	510	490	480	460	440	420	400	380	360	320	
NM8N-630	250A	350	343	332	319	306	300	287	275	262	250	237	225	212	
	315A	441	433	418	402	386	378	362	346	331	315	300	286	271	
	350A	490	481	465	447	429	420	402	385	367	350	332	295	276	
	400A	560	550	530	510	490	480	460	440	420	400	380	360	320	
	500A	700	687	662	637	612	600	575	550	525	500	450	406	360	
NM8N-800	500A	700	687	662	637	612	600	575	550	525	500	490	460	400	
	630A	882	866	836	804	772	756	724	693	661	630	580	530	490	
	700A	980	962	927	892	857	840	805	770	735	700	670	645	575	
	800A	1120	1100	1060	1020	980	960	920	880	840	800	735	670	625	
NM8N-1600	800A	1120	1100	1060	1020	980	960	920	880	840	800	760	696	640	
	1000A	1400	1375	1325	1275	1225	1200	1150	1100	1050	1000	950	870	800	
	1250A	1750	1718	1656	1594	1531	1500	1437	1375	1312	1250	1187	1088	1000	
	1600A	2240	2200	2120	2040	1960	1920	1840	1760	1680	1600	1520	1390	1280	



Note¹⁾ For a multi-pole DC circuit breaker, if a 2m long standard wire is used in series, the derating factor above applies.
²⁾ : When the copper short-circuit bar is connected in series, it needs to be further reduced based on the above table (except NM8NDC-1600). The specific derating factor should be determined by users according to their different wiring methods. Derating by a factor of 0.8).

10.4 NM8N electronic circuit breaker rated operational current and temperature compensation coefficient table

Rated current		Ambient temperature											
		-25°C	-15°C	-5°C	0°C	+10°C	+20°C	+30°C	+40°C	+50°C	+60°C	+70°C	
NM8N-250	32A	32	32	32	32	32	32	32	32	32	32	32	
	63A	63	63	63	63	63	63	63	63	63	63	63	
	100A	100	100	100	100	100	100	100	100	100	100	100	
	160A	160	160	160	160	160	160	160	160	160	160	160	
	250A	250	250	250	250	250	250	250	250	250	240	225	213
NM8N-400	250A	250	250	250	250	250	250	250	250	250	250	250	
	400A	400	400	400	400	400	400	400	400	400	380	360	340
NM8N-630	250A	250	250	250	250	250	250	250	250	250	250	250	
	400A	400	400	400	400	400	400	400	400	400	380	360	340
	630A	630	630	630	630	630	630	630	630	630	600	570	540
NM8N-800	630A	630	630	630	630	630	630	630	630	630	630	630	
	800A	800	800	800	800	800	800	800	800	800	760	720	680
NM8N-1600	800A	800	800	800	800	800	800	800	800	800	800	800	
	1000A	1000	1000	1000	1000	1000	1000	1000	1000	1000	1000	1000	
	1250A	1250	1250	1250	1250	1250	1250	1250	1250	1250	1250	1250	
	1600A	1600	1600	1600	1600	1600	1600	1600	1600	1600	1520	1440	1360

Note: Individual specifications of products need to be derated at a temperature of 50 ° C and above (parameters refer to the table), and I_r needs to be adjusted to the corresponding gear.

For example: NM8N-250 EN 250 3P products are used at 70 ° C. The product needs to be derated to 213A, and the I_r position is adjusted to 0.8I_n position. The NM8N-250 EM 250 3P product is used at 70 ° C. The product should be derated to 213A, and the I_r position should be adjusted to 213A.

10.5 Derating factor table for circuit breaker with residual current protection module

Model	Derating factor	
NM8N-125+NM8NL-125	16A~63A	1
	80A~100A	0.9
	125A	0.8
NM8N-250+NM8NL-250	125A~180A	1
	200A~250A	0.9
NM8N-250+NM8NL-250 electronic type	32A、63A、100A、160A	1
	250A	0.95
NM8N-400+NM8NL-400	250A	1
	315A、350	0.96
	400A	0.93
NM8N-400+NM8NL-400 electronic type	250A	1
	400A	0.95
NM8N-630+NM8NL-630	400A	0.93
	500A	0.87
NM8N-630+NM8NL-630 electronic type	400A~500A	1
	630A	0.90



10.6 Derating factor table for circuit breakers with plug-in or draw-out accessories

Model		Derating factor	
		+Plug-in type	+Economic draw-out type
NM8N-125	16A-100A	1	/
	125A	0.95	/
NM8N-250	125A-180A	1	/
	200A-250A	0.95	/
NM8N-250 electronic type	32A, 63A, 100A, 160A	1	/
	250A	0.95	/
NM8N-400	250A-400A	1	1
NM8N-400 electronic type	250A-400A	1	1
NM8N-630	400A	1	1
	500A	0.95	1
NM8N-630 electronic type	400A-500A	1	1
	630A	0.9	0.9
NM8N-800	500-700A	/	0.95
	800A	/	0.9
NM8N-800 electronic type	630A	/	1
	800A	/	0.9

10.7 NM8N Derating factor table for circuit breakers altitude

Altitude (m)		2000m	3000m	4000m	5000m	
Rated operational current I_n		$1 \times I_n$	$0.96 \times I_n$	$0.93 \times I_n$	$0.9 \times I_n$	
Rated operational voltage U_e (V)	AC	690	550	480	420	
	DC (4pole string)	1000	900	850	800	
Rated insulation voltage U_i (V)		1000	930	870	800	
Dielectric properties (V)	AC	$U_{imp} = 8kV$	2200	2050	1900	1770
		$U_{imp} = 12kV$	2550	2370	2200	2050
	DC	$U_{imp} = 8kV$	3110	2892	2705	2488
		$U_{imp} = 12kV$	3600	3350	3110	2985
Rated insulation impulse voltage U_{imp} (kV)	NM8N-125 NM8N-250 NM8N-1600	8	8	8	8	
	NM8N-400 NM8N-630 NM8N-800	12	10	8	8	

10.8 Cascading (AC220/230/240V)

Upstream	NM8N-125					NM8N-250					NM8N-400					NM8N-630					NM8N-800				
Breaking capacity (kA rms)	C	S	Q	H	R	C	S	Q	H	R	C	S	Q	H	R	C	S	Q	H	R	C	S	Q	H	R
	36	50	70	100	150	36	50	70	100	150	36	50	70	100	150	36	50	70	100	150	36	50	70	100	150
Downstream	Breaking capacity (kA rms)																								
NB1N	25	30	40	60	60	25	30	40	60	60	—	—	—	—	—	—	—	—	—	—	—	—	—	—	—
NB1H	30	40	50	65	65	30	40	50	65	65	—	—	—	—	—	—	—	—	—	—	—	—	—	—	—
NM8N-125C		50	60	80	100		50	60	80	100		50	60	80	100		50	60	80	100		50	60	80	100
NM8N-125S			70	90	120			70	90	120			70	90	120			70	90	120			70	90	120
NM8N-125Q				90	140				90	140				90	140				90	140				90	140
NM8N-125H					150					150					150					150					150
NM8N-250C						50	60	80	100		50	60	80	100		50	60	80	100		50	60	80	100	
NM8N-250S							70	90	120			70	90	120			70	90	120			70	90	120	
NM8N-250Q								90	140				90	140				90	140				90	140	
NM8N-250H									150					150					150					150	
NM8N-400C											50	60	80	100		50	60	80	100		50	60	80	100	
NM8N-400S												70	90	120			70	90	120			70	90	120	
NM8N-400Q													90	140				90	140				90	140	
NM8N-400H														150					150					150	
NM8N-630C																50	60	80	100		50	60	80	100	
NM8N-630S																	70	90	120			70	90	120	
NM8N-630Q																		90	140				90	140	
NM8N-630H																			150					150	
NM8N-800C																					50	60	80	100	
NM8N-800S																						70	90	120	
NM8N-800Q																							90	140	
NM8N-800H																								150	

10.9 Cascading (AC380/400/415V)

Upstream	NM8N-125					NM8N-250					NM8N-400					NM8N-630					NM8N-800									
Breaking capacity (kA rms)	C	S	Q	H	R	C	S	Q	H	R	C	S	Q	H	R	C	S	Q	H	R	C	S	Q	H	R					
	36	50	70	100	150	36	50	70	100	150	36	50	70	100	150	36	50	70	100	150	36	50	70	100	150					
Downstream	Breaking capacity (kA rms)																													
NB1N	20	25	25	25	25	20	25	25	25	25	—	—	—	—	—	—	—	—	—	—	—	—	—	—	—	—	—	—	—	—
NB1H	30	30	30	30	30	30	30	30	30	30	—	—	—	—	—	—	—	—	—	—	—	—	—	—	—	—	—	—	—	—
NM8N-125C		50	50	80	100		50	50	80	100		50	50	80	100		50	50	80	100		50	50	80	100		50	50	80	100
NM8N-125S			70	90	120			70	90	120			70	90	120			70	90	120			70	90	120			70	90	120
NM8N-125Q				90	140				90	140				90	140				90	140				90	140				90	140
NM8N-125H					150					150					150					150					150					150
NM8N-250C							50	50	80	100		50	50	80	100		50	50	80	100		50	50	80	100		50	50	80	100
NM8N-250S								70	90	120			70	90	120			70	90	120			70	90	120			70	90	120
NM8N-250Q									90	140				90	140				90	140				90	140				90	140
NM8N-250H										150					150					150					150					150
NM8N-400C												50	50	80	100		50	50	80	100		50	50	80	100		50	50	80	100
NM8N-400S													70	90	120			70	90	120			70	90	120			70	90	120
NM8N-400Q														90	140				90	140				90	140				90	140
NM8N-400H															150					150					150					150
NM8N-630C																	50	50	80	100		50	50	80	100		50	50	80	100
NM8N-630S																		70	90	120			70	90	120			70	90	120
NM8N-630Q																			90	140				90	140				90	140
NM8N-630H																				150					150					150
NM8N-800C																											50	50	80	100
NM8N-800S																												70	90	120
NM8N-800Q																													90	140
NM8N-800H																														150



10.10 Selective protection

Downstream \ Upstream	In (A)	NM8N-125										NM8N-250					NM8N-250 Electronic							
		16	20	25	32	40	50	63	80	100	125	125	160	180	200	225	250	32	63	100	160	250		
NB1 Tripping curve:B/C	≤ 10	190	190	300	400	500	500	500	630	800	1000	T	T	T	T	T	T	400	500	1000	T	T		
	16			300	400	500	500	500	630	800	1000	T	T	T	T	T	T	400	500	1000	T	T		
	20					500	500	500	630	800	1000	T	T	T	T	T	T		500	1000	T	T		
	25						500	500	630	800	1000	T	T	T	T	T	T		500	1000	T	T		
	32							500	630	800	1000	2000	5000	T	T	T	T		500	1000	T	T		
	40								630	800	1000	2000	5000	T	T	T	T			1000	T	T		
	50									800	1000	2000	5000	T	T	T	T			1000	T	T		
	63										1000	2000	5000	T	T	T	T			1000	T	T		
NM8N-125	16					400	500	500	630	800	1000	1000	2500	2500	2500	2500	2800		500	1000	2500	2800		
	20						500	500	630	800	1000	1000	2500	2500	2500	2500	2800		500	1000	2500	2800		
	25							500	630	800	1000	1000	2500	2500	2500	2500	2800		500	1000	2500	2800		
	32								630	800	1000	1000	2500	2500	2500	2500	2800			1000	2500	2800		
	40									800	1000	1000	2000	2000	2500	2500	2800			1000	2000	2800		
	50										1000	1000	2000	2000	2500	2500	2800			1000	2000	2800		
	63											1000	2000	2000	2500	2500	2800				2000	2800		
	80													2000	2000	2500	2500	2800				2000	2800	
100															2500	2500	2800					2800		
125															2500	2800							2800	
NM8N-250	125																							
	160																							
	180																							
	200																							
	225																							
250																								
NM8N-250 Electronic	32																				1000	2000	2800	
	63																					2000	2800	
	100																						2800	
	160																							2800
NM8N-400	250																							
	315																							
	350																							
NM8N-400 Electronic	250																							
	400																							
NM8N-630	250																							
	315																							
	350																							
	400																							
NM8N-630 Electronic	250																							
	400																							
	630																							

Note: ¹⁾ No content, meaning no selectivity.
²⁾ 1000, which indicates local selectivity, and the number indicates the maximum fault current to achieve selectivity. For example, selectivity below 1000A can be achieved here, and upper and lower circuit breakers above 1000A may operate simultaneously.
³⁾ T, which means that full selectivity is satisfied within the breaking capacity of the lower circuit breaker.

11 .Ordering notice

11.1 Quick selection of circuit breaker

11.1.1 Quick selection of power distribution and motor protection circuit breakers¹

NM8N	-	250	S	TM	-	125	4C	OTHER
Circuit breaker	Frame current(A)	Breaking code	Release type	Rated current(A)		Poles	Special requirement	
NM8N moulded case circuit breaker	125 250 400 630 800	C : 36kA S : 50kA Q : 70kA H : 100kA R : 150kA	M: Magnetic for motor protection TM : Thermal Magnetic for Distribution Protection EN: Electronic Basic for Distribution Protection EM: Electronic Standard for Distribution Protection ENM: Electronic Basic for Motor Protection EMM: Electronic Standard for Motor Protection	TM/M	EN/EM/ENM/EMM	1P : One pole 2P : Two-pole 3P : Three-pole 4B : Four-pole ²⁾ 4C : Four-pole ²⁾		
				125 : 16,20,25 32,40,50,63,80 100,125	—			
				250 : 125,160,180 200,225,250	250 : 32,63,100 160,250			
				400 : 250,315 350,400	400 : 250,400			
				630 : 400,500	630 : 400,630			
				800 : 500,630 700,800	800 : 630,800			
	1600	S : 50kA Q : 70kA H : 100kA	TM: Thermal Magnetic for Distribution Protection EN: Electronic Basic for Distribution Protection EM: Electronic Standard for Distribution Protection	TM/EN/EM	1600 : 800,1000,1250,1600	3P : Three-pole 4B : Four-pole ²⁾ 4C : Four-pole ²⁾	MOD DC110 ³⁾ MOD DC220 ³⁾ MOD AC230 ³⁾ MOD AC400 ³⁾	

Note: ¹⁾ For customer needs beyond the technical requirements of the sample, you can contact the company's sales department or technical department as a special order processing; The body and accessories should be written separately when ordering. If the user requires the factory to assemble the body and accessories, it must be specified when ordering, otherwise the factory will ship separately; Motor protection is only applicable to 3P / 4P;

²⁾ 4B: Neutral poles without protection, can be operated with other three poles; 4C: Neutral poles with protection, can be operated with other three poles.

³⁾ Only NM8N-1600 has motor type

11.1.2 Quick selection of DC circuit breaker

NM8N

Current type	Frame current(A)	Breaking code	Release type	Rated current(A)	Poles	Special requirement
DC : Direct current	125 250 400 630 800	B : 25kA C : 36kA S : 50kA Q : 70kA H : 100kA	TM : Thermal Magnetic for Distribution Protection	125 : 16,20,25 32,40,50,63,80 100,125 250 : 125,160 180,200,225 250 400 : 250,315 350,400 630 : 400,500 800 : 500,630 700,800	1P : One pole ¹⁾ 2P : Two-pole ¹⁾ 3P : Three-pole 4P : Four-pole	
	1600	B : 25kA C : 36kA	TM : Thermal Magnetic for Distribution Protection	1600 : 800,100 1250,1600	3P : Three-pole 4P : Four-pole	

Note: ¹⁾ 1P / 2P is limited to 125 and 250 frame products.



11.1.3 Quick selection of switch disconnecter

NM8N

SD	-	250	AC	125	2P	OTHER
Switch disconnecter		Frame current (A)	Release type	Frame current (A)	Poles	Special requirement
SD : Switch disconnecter		125 250 400 800 1600	AC: Alternating current DC: Direct current	125 : Default 250 : Default 400 : Default 800 : Default 1600 : 800,1000 1250,1600	2P : Two-pole ¹⁾ 3P : Three-pole 4P : Four-pole	

Note: ¹⁾ 2P is only for 125 and 250 frame products.



11.2 NM8N accessory models selection table

Accessory type	Code	Specification	NM8N-125	NM8N-250
Auxiliary contact	AX	Universal	AX21-M8	
		Neutral	AX21-M8 N	
Alarm contact	AL	Universal	AL21-M8	
		Neutral	AL21-M8 N	
Shunt release	SHT	AC48V	SHT21-M8 AC48V	SHT22-M8 AC48V
		AC110V	SHT21-M8 AC110V	SHT22-M8 AC110V
		AC220-240V	SHT21-M8 AC220-240V	SHT22-M8 AC220-240V
		AC380-415V	SHT21-M8 AC380-415V	SHT22-M8 AC380-415V
		DC24V	SHT21-M8 DC24V	SHT22-M8 DC24V
		DC220V	SHT21-M8 DC220V	SHT22-M8 DC220V
Under-voltage release	UVT	AC48V	UVT21-M8 AC48V	UVT22-M8 AC48V
		AC110V	UVT21-M8 AC110V	UVT22-M8 AC110V
		AC220-240V	UVT21-M8 AC220-240V	UVT22-M8 AC220-240V
		AC380-415V	UVT21-M8 AC380-415V	UVT22-M8 AC380-415V
		DC24V	UVT21-M8 DC24V	UVT22-M8 DC24V
		DC48V	UVT21-M8 DC48V	UVT22-M8 DC48V
		DC110-120V	UVT21-M8 DC110-120V	UVT22-M8 DC110-120V
		DC220V	UVT21-M8 DC220V	UVT22-M8 DC220V
Motor-driven mechanism	MOD	AC110/DC110-120V	MOD21-M8 AC110/DC110-120V	MOD22-M8 AC110/DC110-120V
		AC220-240V/DC220V	MOD21-M8 AC220-240V/DC220V	MOD22-M8 AC220-240V/DC220V
		AC380-415V	MOD21-M8 AC380-415V	MOD22-M8 AC380-415V
		DC24V	MOD21-M8 DC24V	MOD22-M8 DC24V
Economic extended rotary handle	SRH	3P	SRH21-M8 3P	SRH22-M8 3P
		4P	SRH21-M8 4P	SRH22-M8 4P
Direct rotary handle	DRH	Thermal magnetic (T)	DRH21-M8 T	DRH22-M8 T
		Magnetic (M)	DRH21-M8 M	DRH22-M8 M
		Electronic (E)	/	DRH22-M8 E
		Switch disconnector (SD)	DRH21-M8 M	DRH22-M8 SD
Extended rotary handle	ERH	Thermal magnetic (T)	ERH21-M8 T	ERH22-M8 T
		Magnetic (M)	ERH21-M8 M	ERH22-M8 M
		Electronic (E)	/	ERH22-M8 E
		Switch disconnector (SD)	ERH21-M8 M	ERH22-M8 SD
Extended rotary handle	LHD	3P/4P	/	/
Locking system	KLK		KLK21-M8	KLK22-M8
Mechanical interlock	MIT	3P	MIT21-M8 3P	MIT22-M8 3P
		4P	MIT21-M8 4P	MIT22-M8 4P
Short terminal cover	TCV	3P	TCV21-M8 3P	TCV22-M8 3P
		4P	TCV21-M8 4P	TCV22-M8 4P
Long terminal cover	TCE	3P	TCE21-M8 3P	TCE22-M8 3P
		4P	TCE21-M8 4P	TCE22-M8 4P
Front connection plate	FCP	1P	FCP21-M8 1P	FCP22-M8 1P
		2P	FCP21-M8 2P	FCP22-M8 2P
		3P	FCP21-M8 3P	FCP22-M8 3P
		4P	FCP21-M8 4P	FCP22-M8 4P
Rear connection plate	RCP	1P	RCP21-M8 1P	RCP22-M8 1P
		2P	RCP21-M8 2P	RCP22-M8 2P
		3P	RCP21-M8 3P	RCP22-M8 3P
		4P	RCP21-M8 4P	RCP22-M8 4P
Cage clamp terminal	CCT	1hole	CCT21-M8	CCT22-M8
Cable connector	MC	1hole	MC21-M8(1)	MC22-M8(1)
		2hole	/	MC22-M8(2)
		3hole	/	/
		4hole	/	/
		6hole	/	MC22-M8(6)
Plug-in base	PIA	3P Front connection	PIA21F-M8 3P	PIA22F-M8 3P
		4P Front connection	PIA21F-M8 4P	PIA22F-M8 4P
		3P Rear connection	PIA21B-M8 3P	PIA22B-M8 3P
		4P Rear connection	PIA21B-M8 4P	PIA22B-M8 4P
Plug-in safety device	PISD	Thermal magnetic (T)	PISD21-M8 T	PISD22-M8 T
		Electronic (E)	/	PISD22-M8 E
Draw-out base	DOB	3P Front connection	/	/
		4P Front connection	/	/
		3P Rear connection	/	/
		4P Rear connection	/	/
DIN-rail adapter	DRA	3P	DRA21-M8 3P	DRA22-M8 3P
		4P	DRA21-M8 4P	DRA22-M8 4P
Communication module	COMA	DC24V	/	COMA22-M8 DC24V 0.5m
			/	COMA22-M8 DC24V 1.5m
			/	COMA22-M8 DC24V 3m
		AC230V	/	COMA22-M8 AC230V 0.5m
			/	COMA22-M8 AC230V 1.5m
			/	COMA22-M8 AC230V 3m
Battery box	PSU		/	PSU22-M8
Phase barrier	PHS		PHS21-M8	PHS22-M8



NM8N-400	NM8N-630	NM8N-800	NM8N-1600
AX21-M8			
AX21-M8 N			
AL21-M8			
AL21-M8 N			
SHT22-M8 AC48V		SHT24-M8 AC48V	SHT25-M8 AC48V
SHT22-M8 AC110V		SHT24-M8 AC110V	SHT25-M8 AC110V
SHT22-M8 AC220-240V		SHT24-M8 AC220-240V	SHT25-M8 AC220-240V
SHT22-M8 AC380-415V		SHT24-M8 AC380-415V	SHT25-M8 AC380-415V
SHT22-M8 DC24V		SHT24-M8 DC24V	SHT25-M8 DC24V
SHT22-M8 DC220V		SHT24-M8 DC220V	SHT25-M8 DC220V
UVT22-M8 AC48V		UVT24-M8 AC48V	UVT25-M8 AC48V
UVT22-M8 AC110V		UVT24-M8 AC110V	UVT25-M8 AC110V
UVT22-M8 AC220-240V		UVT24-M8 AC220-240V	UVT25-M8 AC220-240V
UVT22-M8 AC380-415V		UVT24-M8 AC380-415V	UVT25-M8 AC380-415V
UVT22-M8 DC24V		UVT24-M8 DC24V	UVT25-M8 DC24V
UVT22-M8 DC48V		UVT24-M8 DC48V	UVT25-M8 DC48V
UVT22-M8 DC110-120V		UVT24-M8 DC110-120V	UVT25-M8 DC110-120V
UVT22-M8 DC220V		UVT24-M8 DC220V	UVT25-M8 DC220V
MOD23-M8 AC110/DC110-120V		MOD24-M8 AC110/DC110-120V	MOD25-M8 AC110/DC110-120V
MOD23-M8 AC220-240V/DC220V		MOD24-M8 AC220-240V/DC220V	MOD25-M8 AC220-240V/DC220V
MOD23-M8 AC380-415V		MOD24-M8 AC380-415V	MOD25-M8 AC380-415V
MOD23-M8 DC24V		MOD24-M8 DC24V	MOD25-M8 DC24V
SRH23-M8		SRH24-M8	SRH25-M8
DRH23-M8 T		/	/
DRH23-M8 M		/	/
DRH23-M8 E		/	/
DRH23-M8 SD		/	/
ERH23-M8 T		/	/
ERH23-M8 M		/	/
ERH23-M8 E		/	/
ERH23-M8 SD		/	/
/		/	LHD25-M8
KLK23-M8		/	/
MIT23-M8 3P		MIT24-M8	/
MIT23-M8 4P		/	/
TCV23-M8 3P		TCV24-M8 3P	/
TCV23-M8 4P		TCV24-M8 4P	/
TCE23-M8 3P		TCE24-M8 3P	/
TCE23-M8 4P		TCE24-M8 4P	/
/		/	/
/		/	/
FCP23-M8 3P		/	FCP25-M8 3P
FCP23-M8 4P		/	FCP25-M8 4P
/		/	/
/		/	/
RCP23-M8 3P		RCP24-M8 3P	/
RCP23-M8 4P		RCP24-M8 4P	/
CCT23-M8		/	/
/		/	/
MC23-M8(2)		MC24-M8(2)	/
/		/	MC25-M8(3)(800)
MC23-M8(4)		/	MC25-M8(4)(1000/1250)
/		/	/
PIA23F-M8 3P		/	/
PIA23F-M8 4P		/	/
PIA23B-M8 3P		/	/
PIA23B-M8 4P		/	/
PISD23-M8 T		PISD24-M8 T	/
PISD23-M8 E		PISD24-M8 E	/
DOB23F-M8 3P(400A)	DOB23F-M8 3P(630A)	DOB24F-M8 3P	/
DOB23F-M8 4P(400A)	DOB23F-M8 4P(630A)	DOB24F-M8 4P	/
DOB23B-M8 3P(400A)	DOB23B-M8 3P(630A)	DOB24B-M8 3P	/
DOB23B-M8 4P(400A)	DOB23B-M8 4P(630A)	DOB24B-M8 4P	/
DOSD23-M8 T		DOSD24-M8 T	/
DOSD23-M8 E		DOSD24-M8 E	/
/		/	/
/		/	/
COMA22-M8 DC24V 0.5m			
COMA22-M8 DC24V 1.5m			
COMA22-M8 DC24V 3m			
COMA22-M8 AC230V 0.5m			
COMA22-M8 AC230V 1.5m			
COMA22-M8 AC230V 3m			
PSU22-M8			
PHS23-M8		PHS24-M8	PHS25-M8

