

Product data sheet

Specifications



Floor standing enclosure, PrismaSeT G, W 600mm, H 1880mm (33M), IP30

LVS08204

Main

Range	PrismaSeT
Range of product	PrismaSeT G
Product or component type	Enclosure
Device application	Low voltage electrical distribution
Enclosure type	Functional enclosure delivered in kit form Metal enclosure Indoor enclosure
Enclosure/Cubicle description	Floor-standing enclosure - width 600 mm
Kit composition	uprights rear plate 2 side panel top plate bottom plate plinth
Additional information	Can be combined side by side
Type of front plate	Without to be ordered separately
Number of vertical modules [50 mm]	33
Number of 18 mm modules per row	24
Standards	IEC 61439-1 IEC 61439-2 IEC 62208
Product certifications	ASTA EAC

Complementary

[Ui] rated insulation voltage	1000 V on main rear busbars conforming to IEC 61439-2
Network frequency	50/60 Hz
[In] rated current	630 A at 40 °C conforming to IEC 61439-2
Short-circuit current	50 kA
[Icw] rated short-time withstand current	25 kA 1 s conforming to IEC 61439-1
[Ipk] rated peak withstand current	53 kA conforming to IEC 61439-1
Electrical insulation class	Class I

Material	Treated sheet steel
Protective treatment	Electrophoresis treatment and hot-polymerised polyester epoxy powder
Surface finish	Textured Matt
Colour	White (RAL 9003)
Width	595 mm
Height	1880 mm with plinth:
Depth	205 mm
Product weight	27.3 kg

Environment

IP degree of protection	IP30 with front plate IP40 with door IP41 with door and canopy IP43 with door, canopy and IP43 gasket
IK degree of protection	IK07 with front plate IK08 with transparent door IK10 with plain door
Mechanical robustness	Seismic tests - 2.5G conforming to IEC 60068-2-57

Packing Units

Unit Type of Package 1	PCE
Number of Units in Package 1	1
Package 1 Height	10.5 cm
Package 1 Width	66.0 cm
Package 1 Length	190.0 cm
Package 1 Weight	28.85 kg
Unit Type of Package 2	P2M
Number of Units in Package 2	8
Package 2 Height	97.0 cm
Package 2 Width	120.0 cm
Package 2 Length	202.0 cm
Package 2 Weight	258.0 kg

Offer Sustainability

Sustainable offer status	Green Premium product
REACH Regulation	REACH Declaration
REACH free of SVHC	Yes
EU RoHS Directive	Pro-active compliance (Product out of EU RoHS legal scope) EU RoHS Declaration
Toxic heavy metal free	Yes
Mercury free	Yes
RoHS exemption information	Yes
China RoHS Regulation	China RoHS declaration Pro-active China RoHS declaration (out of China RoHS legal scope)
Environmental Disclosure	Product Environmental Profile
PVC free	Yes

Dimensions

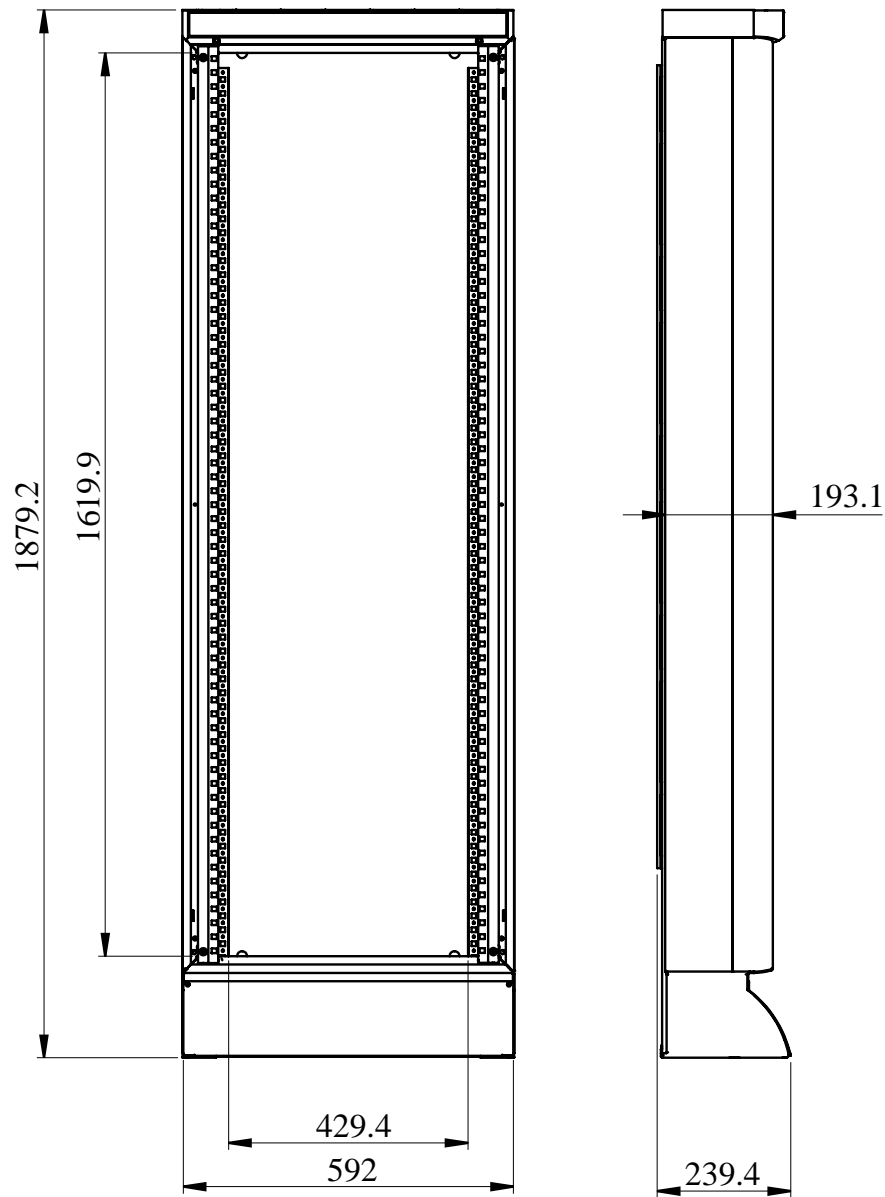

- All dimensions are approximate and are in mm.
- Also see technical documentation.

Recommended replacement(s)