

TECHNICAL CHARACTERISTICS

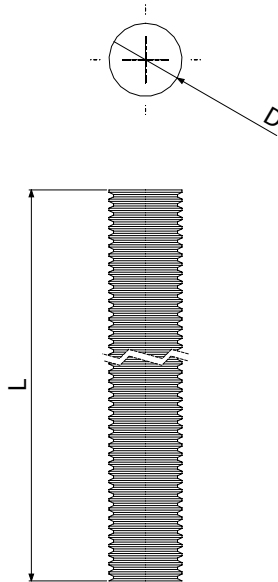

Models: M6; M8; M10; M12.

Finishes: EZ, i304.

Characteristics:

- Length: 1m
- Maximum traction load:

MODEL	Maximum traction (kg)
M6	235
M8	480
M10	820
M12	1245

For the calculation of tensile load, a safety factor of 1.7 (specified in Standard UNE-EN 61537) is considered since the usual use is the mounting of supports for systems of trays or ladders for the conduction of cables.

INSTRUCTIONS FOR USE

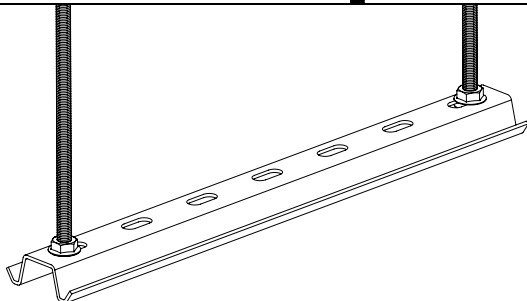
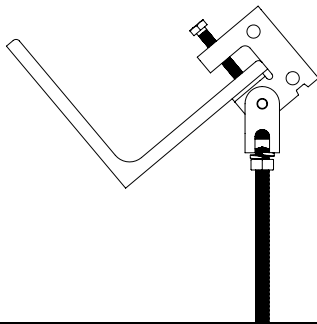

• The mounting of threaded rods with profiles for the construction of swings requires the limiting of the profile arrow to $L/360$ (a more restrictive value than that defined in IEC Standard UNE-EN 61537) since higher deformations can produce turns on the rod reaching collapse.

• The two resting point load values (distributed or struts) of each profile can be seen in the corresponding data sheet. The rod is an element that does not absorb moments and behaves for practical purposes as a strap.

Accessories: Nuts DIN 6923, Nuts DIN 934, Washer DIN 125, Washer DIN 9021, Beam clamp to VR, Variable beam clamp to VR, SBL, SBC, SBZ, variable assembly VR, BASORFIX CM.

Related products: Central Suspension (SSC), simple lateral suspension SLS, suport C-SVO, family BASORPERFIL 41/82, family BASORPERFIL.